



# AEROMAX DTV

Digital Television Audio Processor

## User Guide



---

---



# AEROMAX DTV

Digital Television Audio Processor

## User Guide

Release Date: June, 2007  
Software Version: 0.808 and later



Linear Acoustic Inc.  
Phone: 717-735-3611  
FAX: 717-735-3612  
Web: [www.LinearAcoustic.com](http://www.LinearAcoustic.com)

---

## ***Warranty Information***

**DISCLAIMER OF WARRANTIES:** Products manufactured by Linear Acoustic Inc. are warranted against defects in material and workmanship for a period of two (2) years from the date of purchase. **THERE ARE NO OTHER IMPLIED OR EXPRESS WARRANTIES AND NO WARRANTY FOR MERCHANTABILITY OR FITNESS FOR A PARTICULAR PURPOSE.**

During the warranty period Linear Acoustic Inc. will repair, or at our discretion replace, components which prove to be defective, provided the unit is returned, shipped pre-paid to us directly with a return authorization (RA) number clearly marked on the packaging. **Please note, this RA number must be present or package will be refused and returned to sender.**

All requests for repairs MUST include the unit serial number to ensure quick and accurate service.

**DEFECTS CAUSED BY UNAUTHORIZED MODIFICATIONS, MISUSE OR ACCIDENTS, UNAUTHORIZED CUSTOMER REPAIRS, OR ANY FURTHER DAMAGE CAUSED BY INADEQUATE PACKAGING FOR SERVICE RETURN ARE NOT COVERED BY THIS WARRANTY.**

**PLEASE SAVE THE SHIPPING CARTON AND ALL PACKING MATERIALS. FAILURE TO RETURN UNIT IN ORIGINAL SHIPPING CARTON AND PACKING MATERIALS WILL RESULT IN A CHARGE FOR NEW SHIPPING MATERIALS.**

**LIMITATION OF PERIOD OF ACTION ON CONTRACT:** No action, regardless of form, arising out of the transactions under this agreement may be brought by buyer, its successors, agents and/or assigns, more than three years from date of purchase.

**LIMITATION OF LIABILITY:** It is understood and agreed that Linear Acoustic's liability whether in contract, in tort, under any warranty, in negligence or otherwise shall not exceed the cost of repair or replacement of the defective components and under no circumstances shall Linear Acoustic be liable for incidental, special, direct, indirect or consequential damages, or loss of use, revenue or profit even if Linear Acoustic or its agents have been advised, orally or in writing, of the possibility of such damages.

This product contains Audyne dynamic range processing and is manufactured under license.

AutoNorm, AutoVoiceover, CrowdControl, upMAX, AEROMAX-HDFM, and AEROMAX DTV are registered trademarks of Linear Acoustic Inc., all other trademarks remain the property of their respective owners.

---

# Table of Contents

<b>List of Figures</b> .....	vii
<b>Chapter 1: Introduction</b> .....	5
1.1 Principles of Operation.....	5
1.2 Location of AEROMAX DTV .....	6
1.3 Reference Levels and Line Up Features.....	6
1.4 Reset and Upgrades (What’s Behind Door #3?) .....	6
1.5 Warranty and Feedback .....	7
<b>Chapter 2: Connections and Quick Setup</b> .....	9
2.1 Unpacking and Inspection .....	9
2.2 Installation .....	9
2.3 Rear Panel .....	10
2.3.1 Connection Ports .....	10
2.4 Quick Setup Notes .....	11
2.5 Password Programming.....	11
<b>Chapter 3: Applications</b> .....	13
3.1 Audio Metadata.....	17
3.2 Dolby Digital Encoder Setup (external metadata).....	17
3.3 Dolby Digital Encoder Setup (local metadata) .....	18
3.3.1 Audio Coding Mode .....	18
3.3.2 Dialogue Level.....	18
3.3.3 Dynamic Range Control.....	19
3.3.4 Audience Measurement Systems.....	20
3.3.5 Emergency Alert Systems (EAS) .....	21
<b>Chapter 4: Detailed Operation</b> .....	23
4.1 Menu Navigation .....	23
4.1.1 Modify Processing Menu .....	23

4.1.2	System Info Menu .....	24
4.1.3	System Options.....	25
4.1.4	Test Tones .....	26
4.1.5	GPI/Metadata Setup .....	27
<b>Chapter 5: Specifications.....</b>		<b>29</b>
<b>Chapter 6: Troubleshooting.....</b>		<b>33</b>
6.1	Problems and Possible Causes.....	33
6.1.1	Unit won't power on.....	33
6.1.2	The "LA" symbol is flashing red .....	33
6.1.3	Output Audio Clicks and Pops .....	34
6.1.4	Received Audio Has Dropouts .....	34
6.1.5	Problems with EAS decoding .....	34
<b>Chapter 7: Presets &amp; Processing Adjustment.....</b>		<b>35</b>
7.1	Description of Factory Presets & Adjustments .....	35
7.1.1	..... Processing Structure	36
7.1.2	Adjusting Processing.....	37
7.2	Metadata.....	43
7.2.1	Metadata Structure .....	43
7.2.2	Metadata Setup .....	44

## List of Figures

1-1	Audio Block Diagram .....	6
2-1	Rear Panel .....	10
3-1	AEROMAX-DTV within a typical AC-3 distribution system (ABC) .....	14
3-2	AEROMAX-DTV in a typical baseband PCM system (i.e. NBC). .....	15
3-3	AEROMAX-DTV in a typical HDSDI environment (CBS and others) .....	16
4-1	Locked Main Screen (left); Unlocked Main Screen (right) .....	23
4-2	Recall Preset menu (left) and Save Preset menu (right) .....	24
4-3	System Info menu .....	25
4-4	System Options menu (left) and Preferences menu (right). .....	26
7-1	General signal flow of the AEROMAX-DTV processing core .....	36
7-2	Adjust Processing Menu .....	37





# Chapter 1: Introduction

---

The Linear Acoustic AEROMAX DTV Digital Audio Processor is a state-of-the-art multiband broadcast audio dynamic range processor capable of accepting up to 5.1 channels of audio plus an Emergency Alert System (EAS) signal, processing the audio, upmixing the first pair if desired, and replacing this audio with the EAS input. The unit outputs 5.1 processed channels (or unprocessed when in EAS mode), as well as a full time stereo compatible LtRt version of the main audio channels.

AEROMAX DTV can optionally include metadata functionality where professional audio metadata (i.e. Dolby Metadata) can be applied to the unit to control functions such as upmixing automatically.

The resulting audio is clean, consistent, and appropriately dynamic - perfect for transmission to all consumers via Dolby Digital (AC-3) or any other format. The unit features a simple user interface to allow straightforward control of the unit. Rather than optioning out features, the current unit ships complete with all relevant features providing consistency of operation and sound quality no matter where the unit is installed.

The AEROMAX DTV includes the following features:

- Advanced multiband dynamic range processing for up to six channels of audio; includes input AGC, multiband compression, multiband limiting, distortion free look-ahead peak limiting, and selectable multiband source noise reduction.
- Selectable upmixing of Main Input 1/2 (Left/Right front) using industry standard UPMAX™ 2-channel to 5.1 channel upconversion algorithm
- EAS input that can be remotely commanded to replace audio outputs for insertion of emergency audio program
- LtRt compatible downmix of main audio program available full-time.

## 1.1 Principles of Operation

The AEROMAX DTV processing structures support up to a 5.1 channel main input. Two channel audio can be applied to the first Main Input (1/2) and it can be upmixed to 5.1 channels if desired. Specific processing presets and adjustments are discussed in Chapter 7.

Figure 1-1 shows the internal audio path of the AEROMAX DTV. It should be noted that this diagram is a general representation of signal flow. Please consult the appropriate section of this manual for specific functionality.

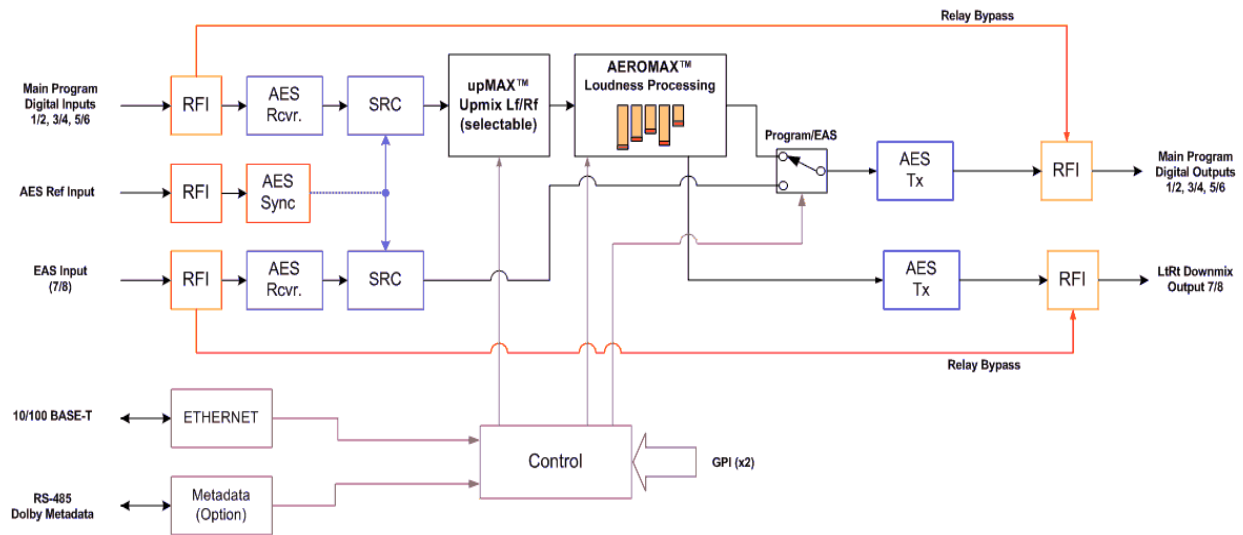

Figure 1-1 Audio Block Diagram

## 1.2 Location of AEROMAX DTV

In the signal flow of a modern television station, audio processors can be placed in a variety of locations depending on how the transmission path is designed. Our suggestion is to try to keep AEROMAX DTV near the Dolby Digital (AC-3) encoder as the units work closely together.

## 1.3 Reference Levels and Line Up Features

The AEROMAX DTV is designed to support a standard reference level of -20dBFS via its digital inputs. Other levels can be supported, but may require adjustments to the presets to avoid under- or over-processing.

The AEROMAX DTV contains a host of built in signal generation capabilities that are useful for both level calibration of downstream equipment, and for channel identification. Please see Chapter 4 for detailed information.

## 1.4 Reset and Upgrades (What's Behind Door #3?)

The “Linear Acoustic” logo on the front panel of the AEROMAX DTV is actually a hinged door. Using your finger or a SOFT instrument, the door can be opened from the left side, and swings out from the unit. Behind this door is a small red push button switch that is used to re-start the unit if it ever enters the so-called “Protection Mode” following an AC power disturbance. See Chapter 6 for more information.

Also behind this logo door is a USB connector for use during software upgrades. Linear Acoustic will provide the proper USB memory device, software, and upgrade instructions as needed. Please do not insert any device into this connector without first contacting the factory as it may impair the performance of the unit and may damage on-air audio.

---

***WARNING: Do not connect any devices to the USB connector behind the logo door without specific instructions from the factory!***

---

## 1.5 Warranty and Feedback

Please take a moment to fill out the postage-paid warranty card included with the unit and drop it in the mail. This will enable us to contact you if there are any software or documentation issues. Also, we are very interested in your feedback. This unit was designed based on input gathered from many broadcast engineers and it will evolve further thanks to ongoing suggestions and comments from users. We look forward to hearing from you!



## Chapter 2: Connections and Quick Setup

---

This chapter covers all required connections for the AEROMAX DTV.

### 2.1 Unpacking and Inspection

Before unpacking the unit, inspect the outer carton for shipping damage. If the carton shows damage, inspect the unit in those areas. Please save the carefully designed shipping carton and packing materials. In the unlikely event that the unit needs to be returned to the factory, alternate cartons or packing materials may not be adequate and can cause damage not covered by warranty.

The following essential items are provided with the unit:

- Bag containing: One power cord (style matches Country of order), this manual, and a handy black pen.
- Warranty information: Please fill out and return the warranty card to Linear Acoustic to ensure your software and documentation are kept up to date.

### 2.2 Installation

AEROMAX DTV installation requires:

- three standard rack space units with ADEQUATE VENTILATION (the unit vents from the front side intake slots to the rear power supply exhaust fan);
- standard 75-Ohm BNC cables for digital signal connections;

To connect to digital equipment with 110-Ohm XLR connectors, use impedance-matching transformers (available from Canare, Neutrik and other manufacturers).

- AES reference supplied to the **AES REF** input *PRIOR* to powering the unit on and at all times thereafter.

## 2.3 Rear Panel

The rear panel of the AEROMAX DTV contains its electrical I/O.

---

**WARNING:** Before applying power, check the **Voltage Selector switch**.

---

### 2.3.1 Connection Ports

All of the AEROMAX DTV's connections are on the rear panel and are described in detail below. See Chapter 5: *Specifications* for specific pinouts.

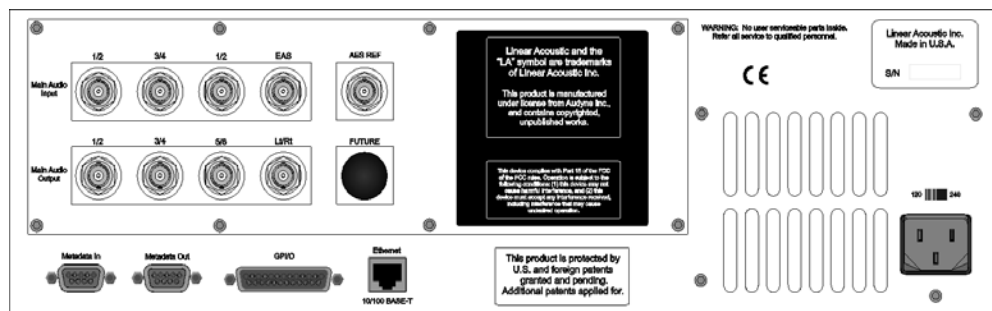

**Figure 2-1** Rear Panel

- **Main Audio Input:** Connect the 48kHz PCM signals to these inputs. The input channels are arranged as follows: 1/2 = Left front/Right front, 3/4 = Center/LFE, 5/6 = Left surround/Right surround, and 7/8 = EAS input.
- **Main Audio Output:** Main 48kHz processed digital audio outputs with same channel configuration as the inputs on 1-6. A compatible LtRt downmix of the main program is available at all times on output 7/8.
- **AES REF:** Connect a 48kHz AES plant reference signal to this connector (*not a video or wordclock reference*). The signal may be an AES Black or AES signal containing audio. All Main Audio Inputs must be synchronous and locked to the AES reference signal applied to the AEROMAX DTV.

---

**NOTE:** 48 kHz AES reference **MUST** be applied for proper operation.

---

- **GPI/O:** Connect to the GPI/O outputs of your routing or master control switcher to control special processor functions. Note that GPI A and B are used to control functions such as Upmixing and EAS processing bypass and require a held contact closure to ground for the duration of the function.

- **ETHERNET:** Automatically senses 10 or 100BASE-T Ethernet connectivity. See the Remote Control section below for more information.
- **Metadata In:** OPTION: RS-485 connection accepts the metadata output of any Dolby equipment (DP572, DP570, etc...) or any Dolby-compatible metadata source. Used to control upmixing and other functions.
- **Metadata Out:** Loop-through of Metadata In.

## 2.4 Quick Setup Notes

The Linear Acoustic AEROMAX DTV is configured at the factory and is ready to go on the air after making the proper input and output connections and determining if upmixing is desired.

The best way to learn the processor is to explore the different settings with audio applied and monitored. There are many factory presets to support many different tastes. Some presets may not sound much different at first, but will perform very depending on program content. Modern broadcast television offers the ability to process less, and even the heaviest presets in the AEROMAX DTV are moderate by comparison to what might be found in traditional NTSC audio processors.

## 2.5 Password Programming

After setup, it is probably a good idea to password-protect the AEROMAX DTV. This will prevent unauthorized or accidental changes to the settings.





## Chapter 3: Applications

---

The AEROMAX-DTV is intended to be used in an emission (transmission) environment. This chapter discusses several applications, including describing how it can be used to support three common US terrestrial network configurations plus one showing how the unit is commonly used at cable and satellite facilities:

- AC-3 at 640 kbps (ABC) or at 384/448 kbps (PBS, FOX and WB)
- Baseband PCM (NBC after distribution via MPEG1 Layer 2)
- PCM/Dolby E within HD-SDI (CBS)

Additional information is provided that explores the challenges and requirements of audio metadata and how it can impact local television station audio setup. Specific descriptions for configuring local Dolby Digital (AC-3) encoders are also provided.

Although each environment has unique requirements, they are also very similar. In all cases, the audio must be brought back to baseband PCM to connect to the Dolby Digital encoder, the same format required by the AEROMAX-DTV. The figures below show how the AEROMAX-DTV can be integrated within each of the environments.

### AC-3 Distribution System

Figure 3-1 shows how an AEROMAX-DTV would be installed in a typical AC-3 distribution system where the network is using high-rate (640 kbps) AC-3 to deliver the 5.1-channel audio. Presently, ABC is successfully using this distribution system for its HD network. Many ABC affiliate stations are also using the AEROMAX-DTV exactly as shown in Figure 3-1.

As there is no way to deliver the professional audio metadata in this scenario, it is simply ignored and default values are set in the Dolby Digital encoder for audio coding mode, Dialogue Level (dialnorm), and Line and RF Mode DRC presets. The audio is then processed by the AEROMAX-DTV so that it matches these metadata defaults. See section 3.3 below for a description of exactly how to set these parameters.

This configuration is almost identical for PBS and FOX networks, except that AC-3 is run at 384 or 448 kbps and is delivered within a standard 19.39 Mbps ATSC transport stream. This allows a local station to use a commonly available transport stream splicer to insert locally generated digital television video and audio streams. Alternately, a station could decode the network audio and video, insert local programming, then re-encode the audio and video for transmission to consumers (resulting in potentially detrimental side effects on the audio due to the loss of metadata).

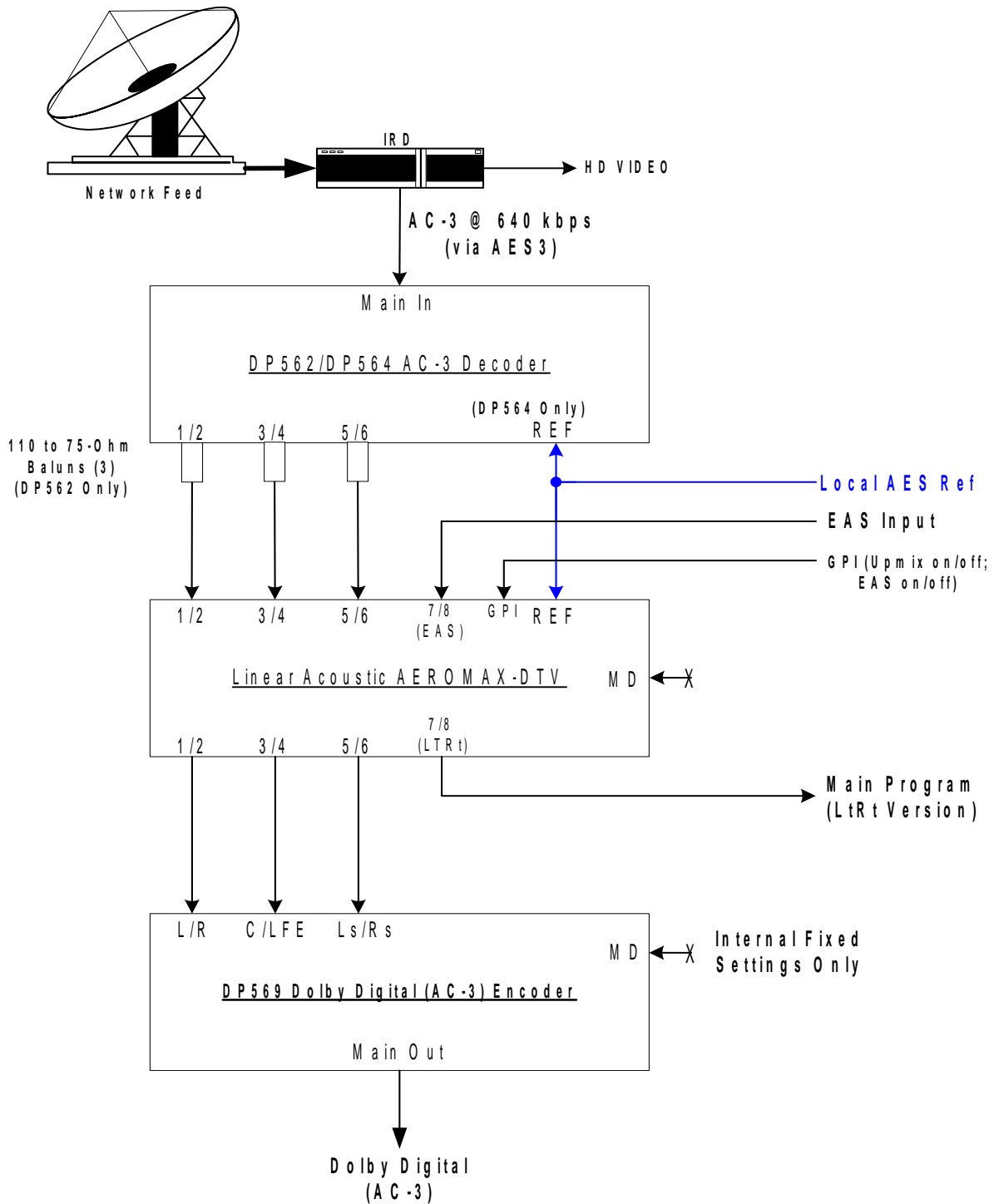
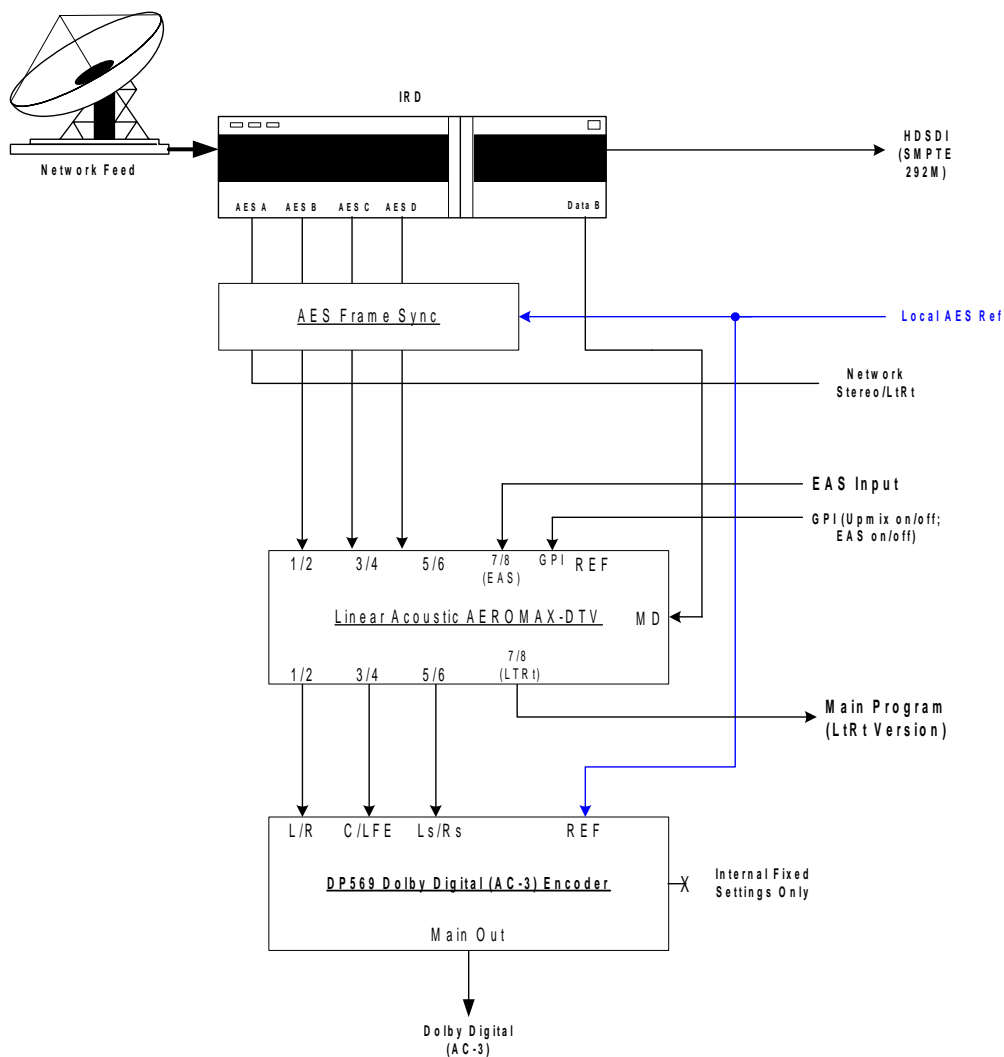

Figure 3-1 AEROMAX-DTV within a typical AC-3 distribution system (ABC)

### PCM Distribution System

Figure 3-2 shows how an AEROMAX-DTV would be installed in a typical PCM distribution system. Note that audio coding will very likely be part of the satellite distribution gear. In the case of NBC, MPEG 1 Layer 2 is built in to the satellite encoder at the network side, and into the IRD (Integrated Receiver Decoder) units at each affiliate station. The system accepts PCM prior to distribution and produces PCM after reception, so it is considered a PCM distribution system.

Note that metadata is carried via the Data B channel of the IRD in the case of NBC. It is standard audio metadata and can be applied to the AEROMAX-DTV directly as shown.



**Figure 3-2** AEROMAX-DTV in a typical baseband PCM system (i.e. NBC).

### HD-SDI Distribution System

Figure 3-3 shows how an AEROMAX-DTV would be installed in a typical HDSDI environment, similar to that in use by CBS network. In this case, professional audio metadata is de-embedded from the HD-SDI signal and is passed to the AEROMAX-DTV where it can be used to control upmixing.

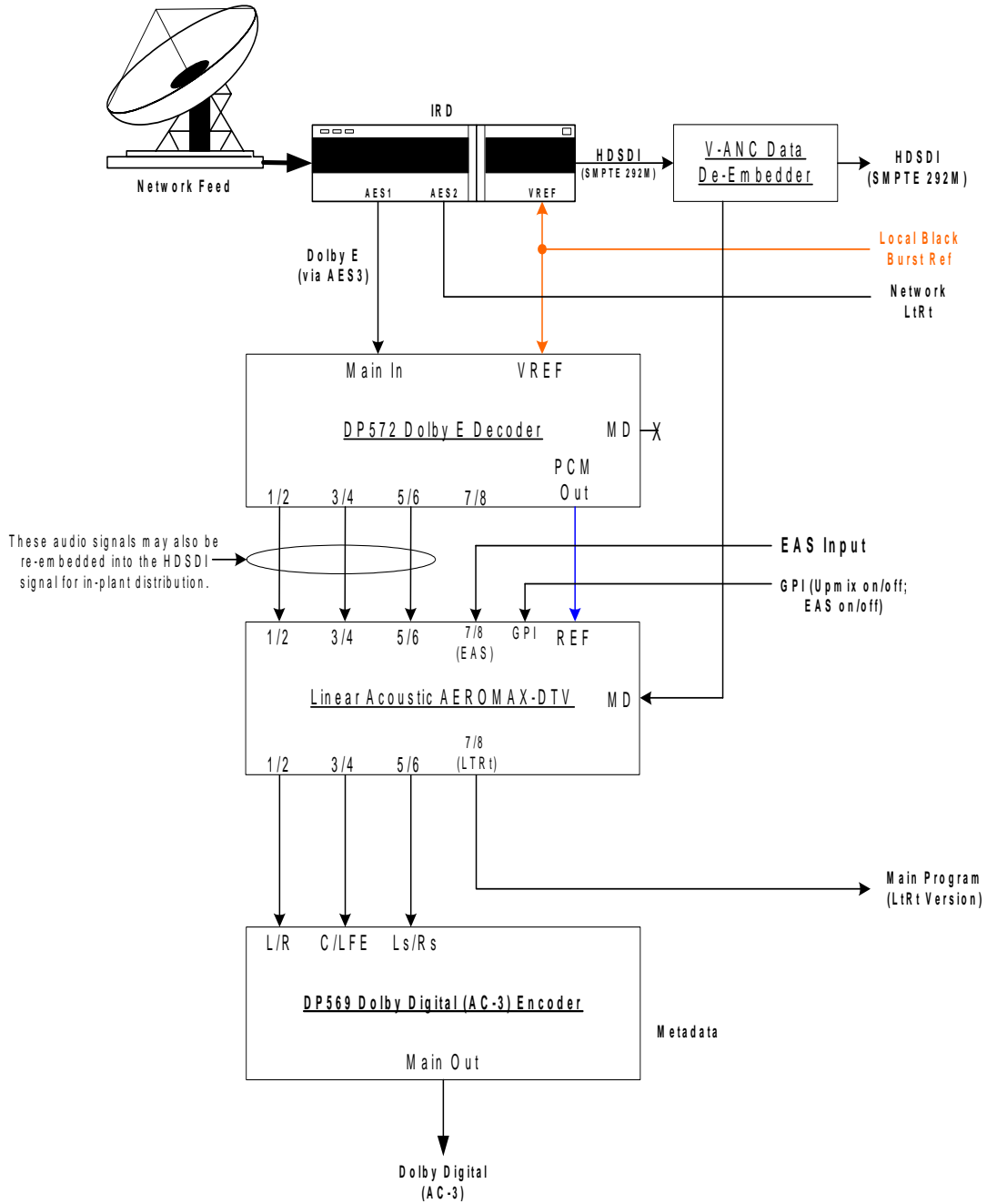

**Figure 3-3** AEROMAX-DTV in a typical HDSDI environment (CBS and others)

The Dolby Digital encoder is set to default values for audio coding mode, dialogue level, and Line and RF Mode DRC presets as described below. CBS network uses Dolby E to carry the audio portion of their HD network feed, and embeds the professional audio metadata along with closed captioning and other data in the VANC space of an HDSDI stream. After receiving the network signal, local stations also have the choice of keeping the signals in baseband format. Note that the REF signal for the AEROMAX-DTV can be obtained easily from the unused PCM Delay output of the DP572, thereby simply locking it to the plant video reference.

All three scenarios show how simply the AEROMAX-DTV integrates into the facility. All three systems also show the product's important "Local" features. Stereo or mono local audio can be applied to the AEROMAX-DTV via either two analog inputs (balanced XLR-type connectors) or a 75-W AES3-ID input (unbalanced BNC). A stereo and matrix surround-compatible LtRt signal is also generated from the main audio program and provided as both a balanced analog and an unbalanced AES3-ID output.

### 3.1 Audio Metadata

Audio metadata, or data that describes the audio data, is used in the AC-3 system to represent important parameters such as the number of channels that have been encoded (audio coding mode or acmod), the loudness of the program with respect to dialogue (dialogue level or dialnorm), and dynamic range control (Line Mode and RF Mode DRC presets). Applied to an AEROMAX-DTV, audio metadata can be used to control functions such as when to apply upmixing and eventually guide processing preset selection. Use of an AEROMAX-DTV with metadata can also protect stations from metadata failure.

### 3.2 Dolby Digital Encoder Setup (external metadata)

In environments where the television network is providing reliable metadata to affiliate stations and the stations are able to access it, the AEROMAX-DTV can work in tandem with this data to ensure audio of the highest reliability and consistency. When installing an AEROMAX-DTV, network audio metadata should be connected only to the AEROMAX-DTV and NOT the AC-3 encoder. The reason for this is that the metadata should be interpreted only once by one device, otherwise values may be applied twice resulting in severe audio problems (such as loss of dialogue).

By analyzing the incoming metadata, features such as upmixing can be automatically invoked when appropriate. The AEROMAX-DTV is also capable of detecting metadata failure and responding appropriately. For example, if metadata were to fail during a 5.1 channel program, upmixing should not be invoked, nor should an AC-3 encoder be switched to 2/0 stereo mode, and both of these situations are prevented.

As the dynamic range, and hence the average loudness of the programming is being

controlled by the AEROMAX-DTV, metadata such as *dialnorm* and DRC presets should be set to fixed values. Suggestions are to set *dialnorm* to the factory default of -27 and select Film Standard for both the Line Mode and RF Mode DRC presets. In this manner, the AEROMAX will automatically pre-adjust the audio to match these settings.

### 3.3 Dolby Digital Encoder Setup (local metadata)

To use the AEROMAX-DTV with a Dolby Digital encoder in an environment without external metadata, such as the type that might be delivered by a network, three critical values must be set in the AC-3 encoder:

- **Audio Coding Mode:** sets the number of channels to encode. Format is Front Channels/Rear Channels: 3/2 is for 5 channel, 2/0 is for stereo. LFE is enabled or disabled elsewhere to create 3/2L for 5.1.
- **Dialogue Level:** sets the dialogue loudness anchor (also known as *dialnorm*). Values vary between -31 and -1 and are correctly set with a dialogue loudness meter such as a Dolby LM100.
- **DRC:** built-in dynamic range control system (also known as Line Mode (*dynrng*) and RF Mode (*compr*), driven by presets such as “Film Standard”.

Note that as they are intimately connected, you must set the dialogue level properly in order for the DRC (dynamic range control) system to perform as intended.

#### 3.3.1 Audio Coding Mode

Also known as *acmod*, this value is shown, for example as 3/2L. This means three front channels, two rear channels, and LFE (i.e. the channel that feeds the sub woofer). Without metadata, it should be set to 3/2 and the LFE turned on so that the up-mixing included with the AEROMAX-DTV can be relied upon to keep all programming in 5.1 channel surround sound.

#### 3.3.2 Dialogue Level

Properly setting the Dialogue Level parameter ensures that the dialogue volume heard by the consumer (or average level in programs without dialogue) is consistent between programs. Contrary to popular belief, there is no one “correct” value for unprocessed audio. As the value indicates the average dialogue loudness of a program and different programs will very likely have different loudnesses, they will also then have different dialogue level values. Correct values are found by measuring each program. This section assumes no metadata is available and that the AEROMAX-DTV is relied upon to match levels between programs. Only in this scenario is it then appropriate to set a single dialogue level value on the AC-3 encoder as the AEROMAX-DTV is doing the job of matching each program to a single loudness value.

To set Dialogue Level:

1. Ideally, use A Dolby LM100 makes this very easy because it displays the actual metadata from the encoded stream and the measured dialnorm value in real time, and the encoder can be quickly adjusted via its front panel.
2. Alternately, you can use the Dolby Digital encoder's remote control program to monitor the dynamic range control activity.
3. With the AEROMAX-DTV set to the desired audio level, simply adjust the Dialogue Level until the minimum amount of gain reduction/expansion (green/red) is shown on the Dolby Digital encoder's remote.

### 3.3.3 Dynamic Range Control

Dynamic range control (DRC) profiles can be selected for RF and Line modes in the Dolby Digital (AC-3) encoder.

---

**NOTE:** *You must properly set the Dialogue Level parameter in order for the DRC profiles to operate correctly.*

---

When using an AEROMAX-DTV preset such as TV 5B Gen or Light (Television 5-Band General or Light), we suggest using is the Film Standard DRC preset in the Dolby Digital encoder for both Line Mode and RF Mode. This allows a small amount of additional gain control to take place in the Dolby Digital encoder and therefore allows consumers to restore some of the dynamic range. The AEROMAX-DTV will still react to badly mismatched loudness levels, but will do so in combination with the DRC profile in the Dolby Digital encoder.

When using the AEROMAX-DTV five-band Heavy preset (TV 5B Heavy), we strongly recommend simply choosing *None* for both Line Mode and RF Mode DRC profiles. In this manner, accidental and unnecessary gain reduction or expansion will not be added on top of what the OCTiMAX is already doing.

#### AC-3 Encoder Metadata Value List

Specific audio metadata parameters that should be set in the AC-3 encoder are:

- Dialogue Level: -27 (with the AEROMAX-DTV in TV 5B Gen)
- Channel Mode (acmod): 3/2
- LFE: On/Enabled
- Line Mode Profile: Film Standard

- RF Mode Profile: Film Standard
- Center Downmix Level: -3dB (0.707)
- Surround Downmix Level: -3dB (0.707)
- DC Filter: On/Enabled
- Low Pass Filter: On/Enabled
- LFE Lowpass Filter: On/Enabled
- Surround 3dB Attenuation: Off/Disabled
- Surround 90-degree phase shift: On/Enabled

Many of these parameters are set to these values by default.

### General AC-3 Encoder Setup

We also *strongly recommend* that the clock setting for the Dolby Digital encoder be set to **Ref In SRC On**. This setting allows the encoder and the AEROMAX-DTV to be locked to the same AES reference, and enabling the SRC (sample rate converters) protects the encoder from any non-standard inputs. The clock should be set this way regardless of whether or not an AEROMAX-DTV is being used because it prevents the encoder from halting if one of the channel pairs is missing or corrupt. We feel that it is far better to have a program on the air missing the surround channels than to have all audio stopped.

Note that when feeding video encoders such as those from Tandberg, an AES reference signal is supplied *by the video encoder* specifically for feeding back to the AC-3 encoder. If the encoder requires this, as the Tandberg models do, it must be used. It seems that this special reference signal is derived from a 27MHz clock that is internal to the video encoder that may or may not be referenced to the plant. Failure to use this reference may cause PTS values to drift when observed on a transport stream monitor, and can cause audible glitches when buffer over or underflow results.

### 3.3.4 Audience Measurement Systems

Systems such as those available from Nielsen (via Norpak) and Arbitron perform their functions by inserting a watermark into the audio signal. For proper operation, it is recommended that these systems be installed *after* any audio processing equipment such as the AEROMAX-DTV to prevent potentially audible unmasking of the watermark signal.



### **3.3.5 Emergency Alert Systems (EAS)**

As EAS systems rely on passing data modulated as audio through the audio channels of a broadcast facility, it is important to ensure that the path is capable of preserving this modulation. Ideally, EAS systems should be inserted after audio processing equipment and this is how the EAS Input of the AEROMAX-DTV unit is configured. Main audio is muted and externally supplied EAS programming is inserted into the Left and Right output channels post processing.



## Chapter 4: Detailed Operation

This chapter discusses in detail the structure of the Linear Acoustic AEROMAX DTV, how to use the front panel LCD interface to access the menus, accessing and saving factory and user processing presets, GPI and Metadata setup, and information about test tone generation features of the unit. Definitions of the processing presets and individual adjustments are covered in detail in Chapter 7.

### 4.1 Menu Navigation

Most of it is rather obvious, and a bit of experimentation will quickly make you comfortable navigating through the submenus. If in doubt, use the Left Arrow to back out towards the Main menu. The menus and submenus are structured to access more complex functionality as you go deeper into the hierarchy.

The left side of Figure 4-1 shows the main screen in *Locked* mode. Once unlocked, the top level of the main screen looks like the right side of Figure 4-1. The meters show input, processing, and output activity for the Main Inputs. The submenus to the right of the meters are used to access the processor's functions, which are described in this chapter.



Figure 4-1 Locked Main Screen (left); Unlocked Main Screen (right)

#### 4.1.1 Modify Processing Menu

The **Modify Processing** menu:

- allows adjustment of all processing parameters - the “Adjust” section is covered in great detail in Chapter 7 of this manual.
- saves and recalls processing presets - All configuration begins with a factory preset but these can be modified, stored, renamed, and recalled. All processing core parameters are saved in the preset.

Saving a preset is a simple procedure. Adjusting any parameter in the **Modify Processing** menu appends an *M* to the name of the original preset to indicate that it has been modified but not yet saved. Figure 4-2 shows the **Save Preset** menu.

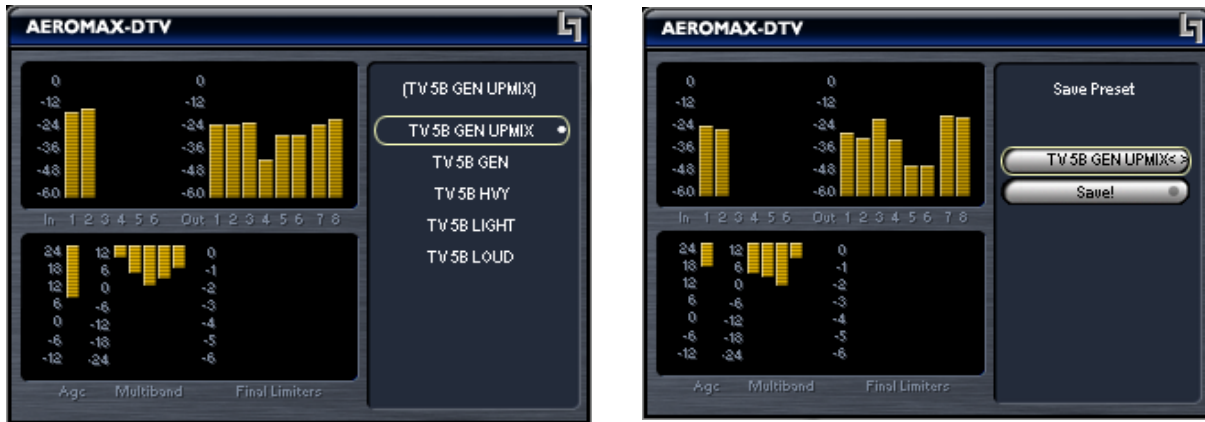

**Figure 4-2** Recall Preset menu (left) and Save Preset menu (right)

The **Save Preset** screen allows you to keep the existing name or rename and save using the arrow keys and the rotary encoder. To rename, press the Up arrow to highlight the current name, then press the Right (Next) arrow to enter edit mode (indicated by the <> symbol), then use the Left and Right arrows along with the rotary encoder to change the preset name. When you are satisfied with the name, press the Down arrow to highlight the Save selection, then press the right arrow to save. If you remove the *M* and attempt to write over the previously saved preset name, you will be prompted to confirm that you wish to overwrite a stored preset.

---

**CAUTION:** The system allows overwriting factory presets, and you will be warned!

---

### 4.1.2 System Info Menu

The **System Info** menu provides the following statistics:

- **Firmware Version**
- **CPU Usage** – Normally around 42%
- **Buffer Size** – The size of the audio buffer in samples.
- **Primary SR** – Average Sample Rate, nominally 48 kHz
- **Up Time** – Operational time since last re-boot.
- **Samples Processed** – This is a useless (but fun) statistic

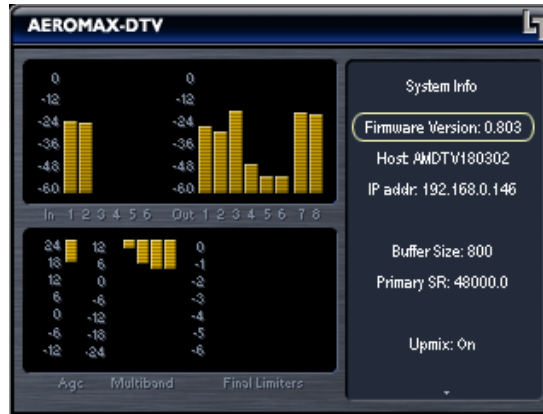

Figure 4-3 System Info menu

### 4.1.3 System Options

The **System Options** menu provides the following functions:

- **Master Bypass** – Relay bypass of Digital Inputs to Digital Outputs
- **Test Tones** - See Below
- **GPI Setup** - See Below
- **Preferences:**
  - **Change Password** – The password is either entered here for the first time or changed. Use the rotary knob and the right arrow key to enter your password, then select **Save**. You will be prompted several times, and then you will be reminded not to lose the password. *Please heed the warning!* If you do happen to lose it, please call us to assist recovery without losing presets. If you wish to remove the password, simply enter the old password, then enter nothing for the new one and select **Save**. You will be prompted a few times, and then it will be removed.
  - **LCD Shutoff** – Select the time-out for the LCD backlight. The backlight turns on once any control is pressed. The unit ships with a two hour setting to prolong the life of the backlight tube. Although the unit is rated for long life, it will not last forever and the entire costly LCD display must be replaced when it fails.
- **Reinitialize** – Fast reset of the system software and audio drivers
- **Save Settings Immediately** – Changes to the system are automatically saved over a period of many minutes in order to minimize the chances of audible clicks and pops that may occur during a save process. However, it is sometimes useful

to be able to save immediately. Selecting this function will do so, and will remind the user that it takes a few seconds even after the function has been performed.

- **Power Cycle** – Slow reset of the entire system. Select this to perform a full system re-boot and re-initialize; you are returned to the main menu.



Figure 4-4 System Options menu (left) and Preferences menu (right).

#### 4.1.4 Test Tones

**Test Tones** – Multiple setup tones are available to calibrate the AEROMAX-DTV and other downstream equipment. The **Level** control is self-explanatory, and is set at the standard  $-20$  dBFS reference level and adjusts the overall level of the test signals. **On/Off** turns the selected test signal on or off while **Cycle** determines which channels will reproduce the selected test signal. It can be adjusted to cycle through all channels, all channels of just the main program (default), and individual channels. The available test signals are:

- Sine – 1 kHz sine wave
- Voice – Voice ID of all selected channels
- Pink Noise – Equal energy-per-octave noise
- White Noise – Equal level-per-octave noise
- Brown Noise – Low-pass-filtered noise
- Brown Nose – Try it (can't be serious all the time)

### 4.1.5 GPI/Metadata Setup

This menu allows configuration of the GPI A, B, and Metadata (GPI C) inputs. Each can be set to provide a specific function that will be active while either of the GPI pin (A or B) is held in a low state, or when the metadata input is active (GPI C). Note that each GPI (A,B,C) must have a different function, meaning that if GPI A is set to Upmix LfRf, then none of the other GPIs can be set for any of the Upmix LfRf functions.

When GPI is enabled (the **Enable GPI** menu item is highlighted), the unit waits for an external command via the GPI/O port and nothing else can be changed. To make a change, disable GPI by de-selecting the menu item.

The available functions include the following:

- Disable
- Upmix Lf/Rf: Off/On; On/Off - Creates a 5.1 channel upmix (i.e. upconversion) from the Channel 1/2 (Lf/Rf) input. Off/On causes upmixing to be engaged upon GPI command, while On/Off is the inverse state where upmixing is on by default and off upon GPI command.
- Upmix Off/Auto; Auto/Off; Auto/On - Upmixing is performed on the Lf/Rf signals, and the output of the upmixer is summed with signals present on the C/LFE and Ls/Rs inputs. This is useful primarily for situations where no GPI contact closure and no metadata commands are available and two-channel and 5.1 channel audio are present within the same three AES pairs and it is impossible to explicitly signal when the audio is in either state. Off/Auto and Auto/Off are self explanatory, but Auto/On is very useful in situations where a user knows that certain content is two channels and desires a full upmix and no feed-through of the remaining channels.
- EAS Mode: Off/On; On/Off - Mutes main program audio and outputs to Left front/Right front the signal present on the EAS Input. Off/On defaults to EAS Mode off and enters EAS Mode upon GPI command while On/Off is the inverse state where EAS Mode is on by default and off upon GPI command.

**Metadata->GPI C State** – A Dolby Metadata compliant signal applied to the Metadata In connector on the rear panel of the AEROMAX-DTV can also be used to drive the above functions. Metadata control of the unit is implemented as GPI C. Normally, metadata is examined to determine if the main program is two channels, and if it is then it can trigger upmixing, Local Input, or Voiceover Input switching. There is also a setting to tell the unit what to do in case of metadata failure. The adjustments are as follows:

- 2 Channel = GPI C On (Off); Default is On

If two channel mode is detected for program one of the incoming metadata stream, then GPI C is activated (GPI C function can be set as described above). If two channel mode is not detected, then GPI C is de-activated.

- Metadata Fail = GPI C (On) Off; Default is Off

Determines what to do should the incoming metadata stream fail. Default is for GPI C to be de-activated. If the incoming metadata stream is valid, then no change to GPI C is made (i.e. normal GPI C functions continue to operate as controlled by metadata). For example, this will allow the unit to stop upmixing if the metadata fails, thereby passing all audio channels straight through.

---

***WARNING: Setting the Metadata Fail to activate upmixing is dangerous. If a 5.1 channel program is present and metadata fails, the dialog will be muted. It is suggested not to choose this mode, or to instead choose Auto Upmix.***

---

Current Metadata: Shows Metadata Program Config or Fail..



## Chapter 5: Specifications

Table 5-1 Electrical Specifications

<b>Sampling Rate</b>	48 kHz ( $\pm 0.1\%$ )
<b>Output Delay</b>	32 msec
<b>Program Configurations</b>	5.1
<b>Audio Word Length</b>	Up to 24 bits
<b>Digital Audio In</b>	Four BNC female connectors: 1/2 = Lf/Rf, 3/4 = C/LFE, 5/6 = Ls/Rs, 7/8 = EAS
<b>Digital Audio Out</b>	Four BNC female connectors: 1/2 = Lf/Rf, 3/4 = C/LFE, 5/6 = Ls/Rs, 7/8 = LtRt
<b>Metadata Input</b>	RS-485, 9-pin female D-connector
<b>Metadata Output (Loop)</b>	RS-485, 9-pin female D-connector
<b>GPIO Port</b>	TTL level, 25-pin female D-connector
<b>Ethernet Port</b>	RJ-45 female connector, 10/100 BASE-T
<b>Digital I/O</b>	
<b>Digital Audio Inputs</b>	Two unbalanced female BNC connectors, comply with AES-3ID-1995/SMPTE 276M. Internal 75-Ohm termination.
<b>Digital Audio Outputs</b>	Two unbalanced female BNC connectors that comply with AES-3ID-1995/SMPTE 276M specifications.
<b>REF Input</b>	Unbalanced female BNC connector, complies with AES-3ID-1995/SMPTE 276M. Internal 75-Ohm termination.

Table 5-2 Mechanical Specifications

<b>Dimensions</b>	5.25 × 19 × 24 in (13.3 × 48.3 × 61 cm)
<b>Net Weight</b>	28 lb (12.6 kg) approx.
<b>Shipping Weight</b>	35 lb (15.75 kg) approx.
<b>Power Requirements</b>	115/220 VAC, switchable, 50–60 Hz
<b>Power Consumption</b>	40 W maximum

Table 5-3 Environmental Specifications

<b>Operating Temperature</b>	0°C to 50°C, fan cooled
<b>Non Operating Temperature (Storage)</b>	-20°C to +70°C
<b>Humidity</b>	Up to 98% relative humidity, non-condensing
<b>EMC Radiation Limits</b>	FCC Part 15 Class A, ICES-003

## Metadata Input Port

9-pin female D-connector with full-duplex RS-485 protocol running at 115 kbps. Pinout is compatible with SMPTE 207M. Pin-for-pin compatible with Dolby metadata sources (i.e. straight-through cable should be used).

Table 5-4 Metadata Input Port Pinout

Pin	Connection
1	Shield
2	TX A asynchronous data out -
3	RX B asynchronous data in +
4	Ground
5	NC
6	Ground
7	TX B asynchronous data out +
8	RX A asynchronous data in -
9	Shield

## Metadata Output Port (Loop)

9-pin female, RS-485, full-duplex, 115 kbps. Pinout is compatible with SMPTE 207M.

Table 5-5 Metadata Output Port Pinout

Pin	Connection
1	Shield
2	RX A asynchronous data in -
3	TX B asynchronous data out +
4	Ground
5	NC
6	Ground
7	RX B asynchronous data in +
8	TX A asynchronous data out -
9	Shield

## Ethernet Port

The Ethernet port is a standard RJ-45 female connector that supports 10 or 100BASE-T.

## GPI/O Parallel Control Port

TTL level controls, active Low. GPI A and B are held low to activate their assigned function, while GPI 1-6 require momentary contact to ground to activate their functions. The 5-V output for external GPO indicators is limited by a self-resetting fuse. Unit Status outputs are dry contact closures.

Table 5-6 GPI/O Parallel Control Port Pinout

Pin	Function	Pin	Function
1	+ 5 V (150 mA)	14	+ 5 V (150 mA)
2	GPI A (Hold Low = On)	15	Ground
3	GPI B (Hold Low = On)	16	Ground
4	RESERVED	17	Ground
5	RESERVED	18	Ground
6	RESERVED	19	Ground
7	RESERVED	20	Ground
8	RESERVED	21	Ground
9	RESERVED	22	Ground
10	Unit Status: Open = OK	23	Unit Status: Common
11	Unit Status: Closed = OK	24	GPO 1
12	GPO 2	25	Ground
13	Ground		

## Chapter 6: Troubleshooting

---

The Linear Acoustic AEROMAX-DTV is a very stable and reliable unit, and most problems can be traced back to mis-wiring causing incorrect signals to be applied to the unit, or more than likely mis-configuration. As simple as the unit is to use once installed, it is very flexible and thus a necessarily complex processor. In an effort to speed troubleshooting, some common problems and solutions are described below.

### 6.1 Problems and Possible Causes

One of the best troubleshooting features of the AEROMAX-DTV is the hard-bypass of the audio signals. This is useful because it allows instant removal of the unit from the signal path. Hard-bypass can be accomplished two ways, the simplest being to remove AC power from the unit by turning the power switch off. A less dramatic way to accomplish the same result is to access the System Options menu and enable Master Bypass. If you are unsure of what is happening in a particular system, simplifying the signal path is a good start and will help isolate problems quickly.

#### 6.1.1 Unit won't power on

First, check to see if the power supply fan is turning when AC power is applied. If the fan is spinning, remember that the boot process may take up to two minutes, and during the process you will hear the bypass relays being cycled. If the fan spins but the unit still does not boot all the way, switch it off, REMOVE THE AC CORD (a bias supply is still active even with the power switch off), wait two minutes, plug it back in and turn the unit on.

If the fan is not spinning, the unit may have shut down in response to an AC power event such as a brown out, or from shutting the unit off during a boot cycle. Either situation may cause the unit to enter protection mode. This helps to ensure that audio will still pass through the unit and that it will not improperly boot causing loss of audio. As revealed in Chapter 1, the “Linear Acoustic” logo on the front panel of the AEROMAX DTV is actually a hinged door. Using your finger or a SOFT instrument, open the door from the left side, swinging it out from the unit. With the unit plugged in and powered on, press the small red push button to take the unit out of protection mode and it will boot normally.

#### 6.1.2 The “LA” symbol is flashing red

The small Linear Acoustic logo in the upper right corner of the display is used to indicate that the reference input is either missing or wildly incorrect. Check to make sure that an AES reference signal is connected to the unit. Note that this signal can be either AES black (i.e. an AES signal with silent audio), or an AES signal with audio. The unit will NOT accept word clock or video reference signals.

### 6.1.3 Output Audio Clicks and Pops

This could indicate that the AES Reference is missing or at the wrong sample rate (the unit expects to be locked to 48kHz). The unit is designed to default to an internal 48kHz reference in case the external reference is removed. This allows audio to continue, but due to the sample rate converters present on each input pair, the outputs will be asynchronous with the inputs. The solution is to make sure that the reference is connected.

It could also mean that audio applied to the unit is not properly referenced, or that the equipment that the AEROMAX-TV is feeding is not properly referenced. Using the master bypass function of the unit is a helpful way to troubleshoot this issue.

### 6.1.4 Received Audio Has Dropouts

The primary cause of this is the Dolby Digital AC-3 encoder not being properly referenced with respect to the DTV video encoder/multiplexer. This is normally accomplished very simply by having all gear referenced to the local plant.

In some cases, such as with certain equipment from Tandberg, a special reference signal is generated in the multiplexer and it needs to be connected back to the Dolby Digital (AC-3) encoder and used as its reference (i.e. set the encoder to “REF IN/SRC On mode). Consult your DTV encoder reference manual for more details.

### 6.1.5 Problems with EAS decoding

It is important to locate EAS encoding equipment after any audio processing, including AEROMAX-DTV. It is critical that processing be minimized for use with current EAS systems.

## Chapter 7: Presets & Processing Adjustment

---

The Linear Acoustic AEROMAX DTV contains multiple factory-programmed processing presets that have been developed after many hours of listening and experimenting, and hundreds of program sources across all genres were used during this tuning. Preset creation is an ongoing process, and we regularly implement presets designed by customers for specific applications.

Of course, all processing controls are accessible and users can custom design special presets that might be even more appropriate for a given situation. We strongly recommend starting with the factory preset that is closest to the desired objective, then fine tuning it to reach the desired goal. This will minimize the troubles that will likely be encountered as many adjustments interact.

### 7.1 Description of Factory Presets & Adjustments

Each unit ships with a number of presets that are useful for most situations. A brief description of each is given below. Following the description of presets, a description of each control available for use by all presets is given. Note that not all presets use every feature. For example, only presets labeled as “NR” will use the multiband source noise reduction feature.

#### Factory Presets

- **TV 5B GEN - TeleVision 5-Band GENeral.** This is the most commonly used preset. It provides a moderate degree of dynamic range processing, and is appropriate for all types of content. It is the factory default for all core preset choices. Use of this preset is highly recommended as it will produce audio that will have an average dialog loudness of -27 as measured by a Dolby LM100.
- **TV 5B GEN UPMIX- TeleVision 5-Band GENeral with UPMIX on.** This is identical to the above, but upmixing has been turned on by default (i.e. no GPI or other setup is required).
- **TV 5B LIGHT- TeleVision 5-Band LIGHT.** This is very similar to TV 5B GEN, however the ratio of the multiband compression has been reduced closer to 2:1 for a more gentle action. Note that this will result in audio that strays further from an average dialog loudness setting.
- **TV 5B GEN - TeleVision 5-Band HEAVY.** Similar to TV 5B GEN, however the ratio of the multiband compression has been increased for a more dense and less dynamic sound.

### 7.1.1 Processing Structure

Before choosing to jump into shark infested waters, we *STRONGLY* recommend starting with a factory preset and modifying from there. Preset creation starting from scratch is an incredibly time consuming process requiring large amounts of time and huge amounts of content spanning all genres including music of every type, films of every type, television dramas and sitcoms of every type, and talking-head programs of every type. We have already done much of the heavy lifting, and provide presets based on our own listening and feedback from customers over the past few years. Certain parameters such as crossover frequencies and channel coupling are not adjustable and are hard-coded to the most appropriate values. That being said, access to all adjustable parameters is provided. There are no factory adjustments hidden from users. Be careful with this power as most all settings interact with each other, sometimes in ways that might not be immediately audible.

Below is a drawing showing the general signal flow of the processing core to indicate what part of the chain is being adjusted by each parameter. Note that this signal flow is also captured in the “Adjust Processing” menu, with the top of the list being the input, and the bottom of the list being the output.

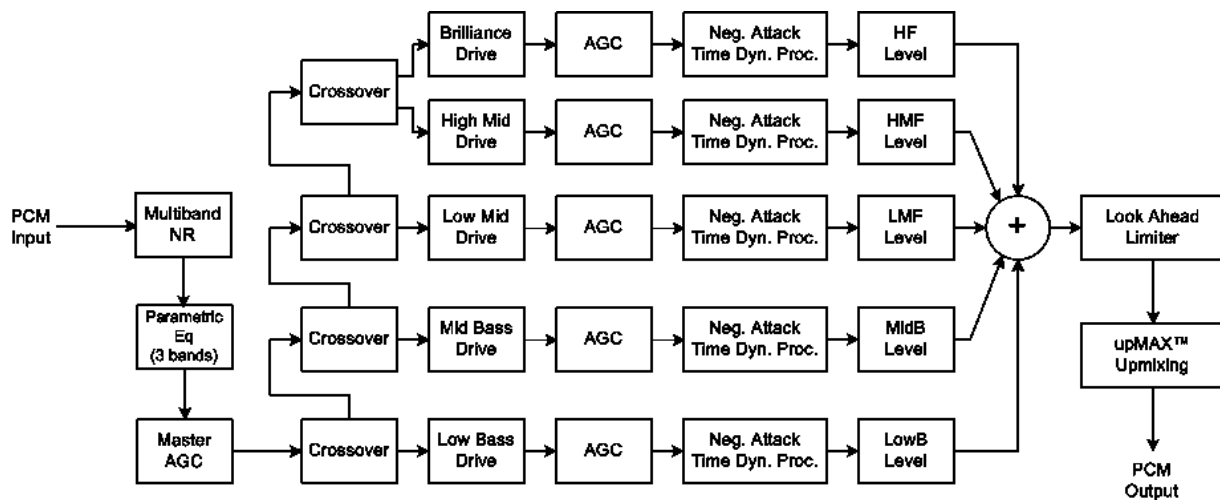

Figure 7-1 General signal flow of the AEROMAX-DTV processing core



## 7.1.2 Adjusting Processing

Following is a description of all adjustable core processing parameters. Defaults are shown for the DTV 5B Gen preset, other presets will obviously vary some or all of these parameters.

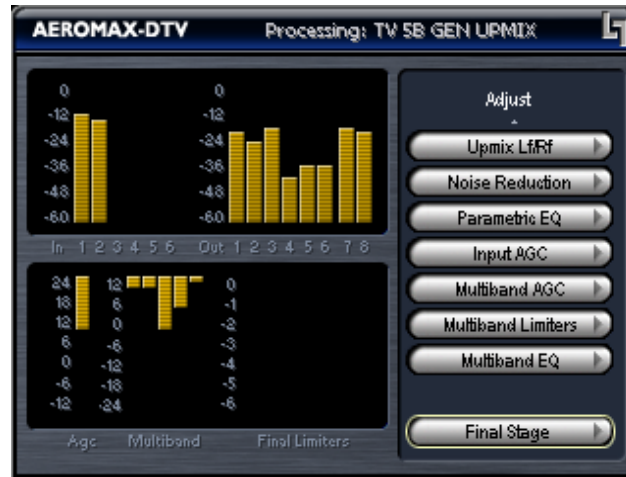

Figure 7-2 Adjust Processing Menu

### But first... A Word on Our Crossovers

The multiband crossovers in the AEROMAX DTV consist of second order Linkwitz Reilly style filters that hard coded to specific frequencies. As the processing required for television applications is not as aggressive as other mediums, little advantage can be gained from changing these values, and the remainder of the processing relies on these characteristics remaining constant.

For reference, the crossover frequencies are:

- Band 1 (Low Bass): 20 Hz - 60 Hz
- Band 2 (Mid Bass): 30 Hz - 200 Hz
- Band 3 (Low Mid): 170 Hz - 1.15 kHz
- Band 4 (High Mid): 950 Hz - 6.1 kHz
- Band 5 (Brilliance): 5.2 kHz - 24 kHz

## Upmixing

Upmixing is the process whereby two channel audio can be re-mapped into 5.1 channels using level and phase detection techniques. The proprietary and industry standard UPMAX™ algorithm is incorporated in the AEROMAX-DTV. This allows for realistic 5.1 channel audio to be created from normal stereo inputs, and performs even better when presented with matrix surround encoded two channel audio (i.e. LtRt). Two channel mono can also be accommodated in an audibly pleasing manner.

Critically, the UPMAX™ algorithm is fully downmix compatible. Many viewers are presented with Dolby Digital (AC-3) encoded audio that is downmixed in their set top box or receiver and they happily listen in stereo, none the wiser that more information is actually present. Upmixing systems that use phase shifting techniques can produce unacceptable results in these systems obscuring dialog and amplifying background artifacts.

There are very few controls required for setup of the upmixer:

- **Enable Center:** On sends center channel audio to the Center output; Off keeps it in Left and Right.
- **Enable Surround:** On sends surround information to the Surround Outputs; Off keeps it in Left and Right.
- **Enable LFE:** On sends bass enhancement audio to the LFE channel; Off disables bass enhancement.
- **Center Width:** controls how much of center channel output of the upmixer is spread back into the Left and Right channel Main Outputs of the unit; The Default is 33% to prevent two channel mono material from being reproduced as stark center channel only audio, and to prevent center channel build-up with music content.
- **LFE Level:** Sets the level of the created bass enhancement signal sent to the LFE output.

## Auto Upmixing

Upmixing is performed on the Lf/Rf signals, and the output of the upmixer is summed with signals present on the C/LFE and Ls/Rs inputs. This is useful primarily for situations where no GPI contact closure and no metadata commands are available and two-channel and 5.1 channel audio are present within the same three AES pairs and it is impossible to explicitly signal when the audio is in either state.

While this process may slightly affect true 5.1 channel programming, it is not possible to “trick” the system. Other methods that use level detection for determining whether programming is two channel or 5.1 can *always* be tricked by certain pro-

gramming. It is impossible to reliably determine the true number of channels simply by the detecting the absence of Center, LFE, and/or the surround channels.

### **Adjust Noise Reduction**

This menu allows access to the multiband source noise reduction controls. Basically a multiband downward expander, source noise reduction can be helpful in situations where aggressive processing is desired, but the source audio contains substantial background noise. Most modern content does not require noise reduction and in general it is recommended that it only be enabled if necessary. Adjustable parameters are:

- Enable: Invokes processing, default is Disabled.
- B1-B5 Threshold (Band 1 - Band 5) - Adjusts the point at which 2:1 expansion takes place, and is variable from -90dBFS to 0dBFS. The lower the setting (i.e. the closer to -90), the earlier the expanders will “open” and stop gating noise. Nominal settings are:
  - B1-B4: -40dBFS
  - B5: -50dBFS

### **Parametric Eq(ualization)**

Three bands of parametric equalization are provided for fine tuning if necessary. None of the factory-supplied presets use the parametric equalizers, but they are provided to create notch filters or other effects if necessary. Each filter has a gain control with a +/-12dB range, a center frequency control that varies from 20 Hz to 22.050 kHz, and a bandwidth or “Q” control that varies between 0 and 10. Normal default settings for all bands are Gain = 0dB, in other words bypassed.

### **Input AGC**

The input AGC is a very slow acting front-end gain control with a 36dB gain range whose only purpose is to make sure that the following processing stages are fed with the correct average audio levels. It is basically the automatic equivalent of an operator slowly riding a gain control on a console to keep the audio close to reference level. Wideband in nature, the AGC is not meant to perform rapid gain reduction or expansion as its actions will be more audible, as with all wideband gain processors. As a slow gain rider, its actions are nearly inaudible thanks to the multiband processing that follows it. The AGC has two stages of gating where the gain expansion is slowed or stopped to prevent background noise increasing.

Adjustable parameters are:

- Gating Thresh(old): 0dBFS to -90 dBFS (default: -30dBFS)

-Gating sets the point at which the AGC release time is made extremely slow to prevent increasing background noise and allow the AGC to return to unity gain.

- Freeze Thresh(old): 0dBFS to -90dBFS (default: -42dBFS)

-Freeze stops all gain change (i.e. when the audio drops to silence), and remains frozen at its current gain value until the threshold is exceeded.

- Ratio: 1:1 to Inf:1 (default: 12.0:1)
- Range: 0dB - 36 dB (default: 24dB)

-Range sets how much gain expansion above unity is performed, and this amount is subtracted from the total AGC gain range of 36dB, so the default value allows for 24dB of expansion and 12dB of compression. This adjustment is reflected in real time by changing the AGC meter scale.

- Threshold: -18dBFS - 0dBFS (default: -16dBFS)
- Attack: 0 - 150, slowest - fastest (default: 21)
- Release: 0 - 150, slowest - fastest (default: 47)
- Progressive Release: 0 - 100, slowest - fastest (default: 50)

-Sets the speed at which the release time is increased faster at very low gain values. This feature approximates a logarithmic release to help recovery from dramatic gain reduction more quickly.

## Multiband AGC

This section is the heart of the dynamics processing engine. A multiband AGC (i.e. compressor) that allows for medium ratio (3:1 is default) adjustment of audio band. Adjustable parameters are:

- Number of Bands: Five Bands/Four Bands (default: five bands)
- Ratio: 1.0:1 - Inf:1 (default: 3.0:1)
- B1-B5 Inf:1 Above Thresh: Enabled / Disabled (default: B1: Enabled, B2: Enabled, B3: Disabled, B4: Disabled, B5: Disabled)

-AGC automatically increases ratio to Infinity:1 once a signal exceeds the threshold (set below), allowing for expansion below the threshold and limiting above the threshold. Useful for bass frequency control.

- Range: 0dB - 24dB (default: 24dB)

-Range sets how much gain expansion above unity is able to be performed. This adjustment is reflected in real time by changing the AGC meter scale.

- Progressive Release: 0 - 100, slowest - fastest (default: 50)

-Sets the speed at which the release time is increased faster at very low gain values. This feature approximates a logarithmic release to help recovery from dramatic gain reduction more quickly.

- B1 - B5 AGC Attack: 0 - 150, slowest - fastest (defaults: B1:46, B2:88, B3:88, B4:88, B5:92)

-How fast an input signal is acted upon once it crosses the set threshold

- B1 - B5 AGC Release: 0 - 150, slowest - fastest (defaults: B1:50, B2:60, B3:86, B4:88, B5:92)

-How fast an input signal recovers from a gain change once that signal falls below the set threshold.

- B1 - B5 AGC Drive: -12.00dB - +12.00dB (default: -3.00dB all)

-A gain control at the input of each compressor band, determines how much signal level is applied to each.

- B1 - B5 AGC Thresh(old): -12.00dB - +12.00dB (default: 0.00dB all)

-The reference point for the attack and release parameters to act on the audio signal present in that band.

## Multiband Limiters

Performs multiband limiting of the signals coming from the multiband compressor.

- B1 - B5 Lim(it) Thresh(old): +12.00dB - 0.00dB (default: B1:+4.25dB, B2:+4.25dB, B3:+6.50dB, B4:+9.00dB, B5:+9.00dB)

-The point above which limiting action takes place at an Infinity:1 ratio.

- B1 Soft Clip Thresh(old): +12.00dB - 0.00dB (default: +3.00dB)

-The point above which band one (low bass) is soft clipped. This helps maintain a “tight” bass sound.

## Multiband EQ

This is the section where each of the processing bands is summed and where overall frequency response can be tailored.

- B1 - B5 Out(put) Mix: -12dB - + 12dB (defaults: 0dB, all bands)

-Sets the mix level for each band summing all bands back together. These controls are prior to the final look ahead limiter and increasing gain may cause more final limiting (possibly more than desired)

## Final Stage

This final section of the processor is where the final look ahead peak limiter and bass soft clipper are adjusted. The look ahead limiters are wideband, limited to 6dB of gain reduction, are extremely fast, and due to their look-ahead nature are virtually transparent even at full gain reduction. Their purpose is to control peaks that make it through the multiband section. Adjustable parameters are:

- Final Limiter Drive: -6dB - +6dB (default: -3dB)

-Sets the level at which the wideband sum of all bands is fed to the final limiter.

- Output Level: -36dB - 0dB (default: -11dB)

-Sets the output level for the current preset. Can be used to match the measured loudness of one preset to another. This is useful as more aggressive presets will measure differently from less aggressive versions.

## 7.2 Metadata

Metadata in the context of television audio is data that describes the audio data. Parameters describe program-specific things like the number of channels and the dialog loudness of a program. These values are intended to be set by the program producer, flow through the entire broadcast chain, and finally used to present a consistent audio experience to the consumer.

As more program producers begin to embrace some of the benefits of metadata, the system as a whole continues to improve, however protection against bad or missing metadata must still be provided. All it takes is for one errant program to have the wrong values or be missing values completely and the presentation suffers. Complaints of loudness shifts between commercials and programs, and image shifts between stereo and surround sound programs are still all too common.

The goal of Linear Acoustic products has always been to provide the best possible delivery of the original audio to consumers within the bounds of what is acceptable. Certainly a program that is produced very loudly and signalled as being very soft is pure abuse of the system and this must be prevented or at least minimized.

### 7.2.1 Metadata Structure

Audio metadata, also known as Dolby or Dolby compatible metadata can be broken down into two parts: professional and consumer. Professional audio metadata describes things like program configuration (i.e. the 5.1+2 seen on Dolby E or Linear Acoustic e-squared systems) and carried up to eight consumer metadata programs. The consumer metadata programs directly correlate to the program configuration, so 5.1+2 is two programs and each has its own set of consumer metadata parameters.

Consumer metadata contains the dialog loudness and audio coding mode parameters that can be used to preserve original audio quality. By using these parameters directly prior to Dolby Digital (AC-3) encoding, the consumer is presented with the best possible representation of the original audio, while not allowing loudness or image shifts.

For a more in-depth description of individual metadata parameters, please refer to the included ATSC document: IS-318 and visit:

[http://www.linearacoustic.com/pdf/Metadata\\_Enc\\_Dec.pdf](http://www.linearacoustic.com/pdf/Metadata_Enc_Dec.pdf)

---

## 7.2.2 Metadata Setup

The AEROMAX 5.1 has been designed to take best advantage of metadata. The incoming Dolby or Dolby-compatible metadata stream is parsed on a program-by-program basis, and the dialog loudness and audio coding mode (channel count) parameters are used to scale processing and control upmixing respectively. Setup of metadata can be accomplished in the Modify Primary (or Modify Secondary) menu, under the Metadata sub-menu.

The setup procedure is described below:

- **Source: PGM1 to PGM8** - Describes which consumer metadata program will be used to control the processing. For an incoming 5.1+2 metadata stream, the Primary processing core should be set to respond to PGM1, while the Secondary processing core should be set to respond to PGM2 (if desired). Factory defaults are PGM1 for Main processing, and PGM2 for Secondary processing.
- **Apply Dialnorm: Yes/No** - If set to yes, then the incoming dialnorm parameter is applied to the incoming audio to scale it prior to processing. Basically, this allows the audio to be centered in the minimum activity area of the processing. If dialnorm was set correctly upstream, then the processing will be minimal. If dialnorm does not match the audio, the AEROMAX 5.1 will realign it in real time.
- **Global def dialnorm: 0 to 31** - Global default dialnorm determines what value should be used in case incoming metadata fails or is intentionally missing. Factory default is 24.
- **Metadata (status): Fail/OK** - indication of incoming metadata stream
  - **acmod:** 3/2L, 2/0, etc... per incoming metadata. Shows N/A in case of failure.
  - **dialnorm:** -1 to -31 per incoming metadata. Shows N/A in case of failure.

It is important when the system is set up that metadata be applied to the AEROMAX 5.1 only, and does not continue on to the Dolby Digital (AC-3) encoder, else the values will be doubly applied. Please see Chapter 3 for encoder setup information.

---

**NOTE:** *The AEROMAX 5.1 should be the last device in the metadata chain to prevent double application of metadata values.*

---



**Notes:**

