

25-Seven Systems

PROGRAM LENGTH MANAGER®



Operator's Manual

Version 1.1



THE TELOS ALLIANCE

It's About Time™

www.25-seven.com 888.257.2578 24-hour tech support 216.622.0247

Warnings and Service Information



CAUTION

TO PREVENT RISKS OF ELECTRIC SHOCK,
DO NOT ATTEMPT TO SERVICE THIS UNIT.



DANGER: There are hazardous voltages in this unit. Do not attempt to repair it.

WARNING: To reduce the risk of electrical shock, do not expose the chassis to rain or moisture.



There are no user-serviceable parts in the Program Length Manager. If repairs are necessary, contact Customer Service at 888.257.2578 (toll-free), our fulltime tech support line 216.622.0247, or write to info@25-seven.com.

USA CLASS A COMPUTING DEVICE INFORMATION TO USER. WARNING: This equipment generates, uses, and can radiate radio-frequency energy. If it is not installed and used as directed by this manual, it may cause interference to radio communication. This equipment complies with the limits for a Class A computing device, as specified by FCC Rules, Part 15, Subpart J, which are designed to provide reasonable protection against such interference when this type of equipment is operated in a commercial environment. Operation of this equipment in a residential area may cause interference. If it does, the user will be required to eliminate the interference at the user's expense. **NOTE:** Objectionable interference to TV or radio reception can occur if other devices are connected to this device without the use of shielded interconnect cables. FCC rules require the use of only shielded cables.

© 2013, 25-Seven Systems, A Telos Alliance Company. All rights reserved.

We are constantly working to improve our products. Specifications and features are subject to change without notice.

THE TELOS ALLIANCE™

Telos®

Omnia®



L LINEAR ACOUSTIC®

1241 Superior Avenue Cleveland, OH 44114 USA | +1.216.241.7225 | TelosAlliance.com

Table of Contents

About this Manual	4
Program Length Manager at a Glance	4
Basic Operation	5
Stretching a program	5
Shrinking a program	9
Shrinking to a target	10
Time manipulation and speed selections	15
Front Panel	15
Detailed Operating Instructions	16
PLM's Front Panel Menus	17
Don't confuse dBu with digital dBFS!	19
About NTP	22
Graphical User Interface and Browser Control	25
Login instructions	25
Remote control	28
Installation	30
Rear Panel	31
Axia / Livewire setup	35
Introduction	35
Network Setup	36
Troubleshooting	40
Software Updates and Factory Access	41
Specifications	41
For more Information	42
Warranty	42



Close-ups

Some parts of this manual explain how Program Length Manager works "under the hood". We've set these in a san-serif face.

You don't need to read these sections to operate or install the system... but they're interesting, and understanding them will help you use the system better.

About this Manual

These pages will help you get the most out of the Program Length Manager™ (PLM).

- The first pages describe PLM'S basic concept and operation: if you're facing a unit that's already installed in a rack, this may be all you need.
- The next pages detail PLM's operating modes, and how to choose the best ones for your operation.
- Then there's a detailed explanation of all the menus and controls, and instructions for setup and installation.

Program Length Manager at a Glance

Program Length Manager (PLM) is a unique, easy to use time compression/expansion processor that allows you to stretch or shrink audio programs in real time. Think of PLM as a high-quality, rugged digital stereo recorder... with some important differences: it can record part of a show while playing back another part, and playback speed can be as much as 20% faster or slower than the original program. In effect, you can use PLM to shorten the duration of programs, allowing you to insert additional material with no loss of content, or stretch programs that are too short so they precisely fill their allotted time slot. PLM does this without pitch change, artifacts, or glitches, thanks to our proprietary processing algorithms; with most broadcast material, a 10% speed change—6 minutes per hour—is virtually undetectable by most listeners.

25-Seven's Program Length Manager combines some of the functions of our award-winning Audio Time Manager with other unique features:

And of course, PLM offers the flexibility and smart design you expect from 25-Seven:

- Glitch-free time compression using technologies developed for 25-Seven's ground-breaking Audio Time Manager®.
- New time expansion algorithms for seamlessly stretching short shows to fit allotted time slots.
- Stereo processing with CD quality, even during time manipulation. It's clean enough that you can use it on music programs and live events.
- Easy operation from the front panel, wired remote, or producer's computer.
- Total flexibility: PLM can expand audio without using filler material, by seamlessly stretching live audio. Or it can shrink audio allowing you to insert additional content.
- Flexible front-panel LCD "dashboard" with controls for time readout, audio level display, and quick parameter changes without a computer.

- Complete, easy to use, password-protected configuration and control from any browser. No need to navigate through menus. Use PLM’s graphic user interface from any computer on your local or wide area data network.
- Flexible audio configuration: XLR version includes separate stereo analog and AES/EBU inputs and outputs.
- Flexible remote control:
 - Use GPIO (buttons, relay closures, or TTL), secure Web interface, RS-232 or serial control over an IP port.
 - GPIO functions can be assigned by the user.
 - Simple serial language for custom control.
 - Network cues can be automatically delayed to match program audio.
 - Automatic clock synchronization to local or Network Time Server.
 - Optional Axia Livewire™ IP audio capability.

For more details on what PLM does and its special features, read on!

Basic Operation

PLM can either time compress (shrink) programs, or time expand (stretch) audio. For quick time compression operations, users can simply follow the BUFFER+PLAY example found on Page 9. But when stretching a program to make it longer, or in certain cases where you want to shrink a show to a target length, you need to enter a little more data before PLM knows what you are trying to do.

Stretching a program

When you start an operation the screen should look like this:

```

  PLM is Ready
  Realtime Play
    10:32:00
  Start→           Menu√
  
```

There is nothing in Delay memory.

*The current time is 10:32. PLM can display time in 12 or 24 hour modes
Press the right arrow key → to start an operation, or Press the √ check mark
to enter the configuration menus.*

In order to stretch a program, PLM needs to know how much time you want to add.

Press the → Right arrow key to Start. You’ll see the following screen, and the “Stretch-by” value on the 3rd line will be flashing, indicating it is currently selected.

```

  Input time: 56:00 →
  Output time: 58:00 ←
  Stretch by: 2:00 ↑↓
  Cancel x           Set√
  
```

The → key will select the Input Time for adjustment.

The ← key will select the Output Time for adjustment.

The ↑↓ keys adjust the current selection; in this case, the Stretch-by time

Press the √ key to confirm values

- The Input time is the actual duration of the program you want to stretch.
- The Output time is the target size you want the program to be.
- The difference between the two is the “Stretch-by” time

When you open this screen, values for Input and Output times will be the same as the last time PLM was used. The Stretch-by time is obviously the difference between the Input and Output, so whenever you alter either Input or Output times, it will drive changes to the Stretch-by value. You can adjust any of these three values. Use the left ← and right → arrow keys to select which field you want to adjust: the flashing field indicates the current selection. As you adjust either the Input time or Output time, the Stretch-by time display will update. You can adjust the Stretch-by time directly: doing so will alter the Input time. Output time is anchored and will not change if you adjust the Stretch-by field, since this target program length is considered a fixed amount in any program hour.

Once you have entered your time values, press `set√`. The screen will update with this display. PLM is now ready to stretch a program.

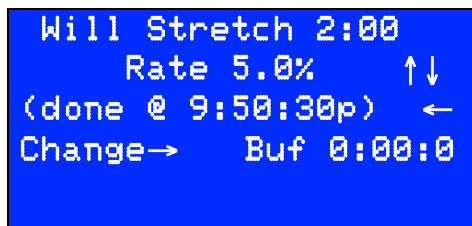

*2:00 is the target amount to stretch by.
 The ↑↓ keys adjust the rate of time expansion.
 The ← key toggles display between clock time and countdown to completion. The → key takes you to the previous screen where you can adjust the Input/ Output times and Stretch-by value.*



The PLAY button will start flashing, prompting you to press it when ready. When you start playback of the program you want to stretch, press PLAY simultaneously.

As the stretch operation begins, the PLAY button will light solidly and the display above will update to reflect your progress.

- The Buffer display will steadily increase until the target is achieved.
- You can change the rate of time expansion using the ↑↓ keys. The higher the rate, the slower speech will sound and the sooner the target will be reached.
- As you adjust the rate, the time to completion is altered. Make sure you choose a rate that will finish your stretch operation on schedule.
- Press the ← key to toggle between viewing done @ and done in times. Done @ is the actual time¹ that the operation will complete, and done in is a countdown display indicating how much time the stretch will take.

¹ For best results, make sure to set up network time protocol (NTP) so that PLM's clock stays accurate.

- If you made a mistake entering the amount of time to stretch, you can make changes, even once time stretching has started. Press the → button to return to the previous screen where you can edit values. Confirm changes by pressing the Set/ button.

Once a stretch operation is complete, the LCD screen will update accordingly:

```
Stretching 2:00
      Rate 5.0%  ↑↓
<(target reached) ←
Change→      Buf 2:00:0
```

2:00 is the target amount
 The ↑ ↓ keys adjust the rate of time expansion.
 Once the target is reached, the ← key has no effect
 The → key takes you to the adjust screen where you can re-adjust the Input/ Output times. The buffer value indicates you are running a static 2:00 delay.

Upon reaching the target (2:00 in our example) time expansion will cease and audio play out will return to normal speed. However, PLM will now be running a 2:00 delay, so any incoming audio will take 2:00 from the time it enters the unit to the time it plays out. PLM has no way of knowing what constitutes the end of a program, so it is important that operators enter an Input time that matches the actual length of the program being stretched, and that stretching starts at the same time the program begins.

PLM will continue to run this 2:00 delay and the PLAY button will stay lit until the operator determines the program has finished playing out and it is safe to end the session.

Completing a Stretch Session

To end a Stretch session, press the red RESET button. Upon the first press, a confirmation screen will appear.

```
**Reset PLM? **
Buffer contents will
be discarded!
CancelX      OK✓
```

Warning screen when RESET is pending
 X cancels, ✓ or pressing RESET again confirms and discards the buffer.



Pressing the RESET button a second time will confirm that you want to exit the session, discard any audio in the buffer, place the unit in real-time play mode, and return to the Start screen. If you pressed RESET by mistake, simply press the X button to cancel. The Reset confirmation screen will time out in 15 seconds if you do nothing.

Optimizing Expansion Rates

Less is more when applying time compression or expansion. The lower the rate you run PLM at, the less noticeable any changes will be to the listener. For most audiences, 5% or less (5% = 3 minutes per hour, and is the factory default rate) will be imperceptible, even on music, and rates of 10% are generally fine for speech. More aggressive rates

may be more noticeable to some listeners on certain program types, and very high rates may introduce some artifacts on expansion processing. Optimizing rates to spread the time compression or expansion process out over as much available time as possible will yield the best results.

In our example of stretching a 56:00 program by 2:00 to fill a 58:00 length time slot, an expansion rate of 3.7% would mean that the process would take 56:04 to complete. This rate is both subtle and safe, since it will insure that expansion has completed by the time the last portion of program audio exits PLM's buffer at 58:00.

Conversely, a lower rate of say, 2.5% would take about 1:19:00 to complete. This rate would not be aggressive enough to stretch the incoming program in our example by 2:00 before the show finished feeding into PLM.

At the other end of the speed spectrum, a rate of 10% would finish stretching the audio by 2:00 a mere 22:00 minutes into the program. The first half of the show would sound substantially slower than the second half, and to no real operational advantage. In most cases, spreading the stretching process out over a longer period is the best way to operate PLM.

There is a simple way to calculate how long it will take to stretch a program at various rates:

- Press Start, and enter Input / Output and stretch times.
- Press Set so that the PLAY button is flashing. PLM is now ready to start stretching. But now, just leave it flashing so you can see how different rates will drive timer calculations
- You can now use the up/down arrow keys to vary the rate. The minimum rate is 1%. The Maximum rate is 20%. Note: You can set a lower Maximum rate in the Control menu to prevent operators from running rates you consider too aggressive.
- Use the left arrow ← to toggle between the “done @” time and “done in” countdown meter. As you change the rate, these time displays will update, showing you either how long until, or when your stretch operation will finish.

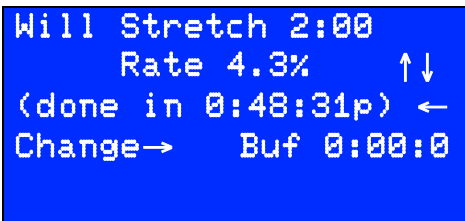

Will Stretch 2:00
Rate 4.3% ↑↓
(done in 0:48:31p) ←
Change→ Buf 0:00:0

*2:00 is the target amount to stretch by
The ↑ ↓ keys adjust the rate of time expansion.
The ← key toggles display between clock time and countdown to completion
The → key takes you to the previous screen where you can adjust the Input/ Output times and Stretch-by value.*

In our earlier example, a rate of 4.3% will finish stretching our 56:00 show well before it has finished feeding into PLM.

As a general guide, all the following speed settings in this table will work to stretch a 58:00 long program into an hour long program. Note that the 3.5% rate does not leave

much margin; it will complete stretching just slightly before the program's 1 hour time slot ends. Note that notching this setting down a mere .1% to 3.4% would require 1:00:50 to stretch the program, and would only reach the target after the show ended, resulting in a problem on air.

Speed setting	Minutes:seconds needed to stretch a 58:00 program by 2:00 to 60:00
3.5%	59:09
5%	42:00
7%	35:35
12%	18:41

Shrinking a program

Instructions for compressing (shrinking) a show are similar to expanding or stretching. But please note the critical differences between the two:

- In order to shrink a program, there must be audio in the buffer. This means you need to record audio into PLM and have it buffer before you go to air,
- When the Buffer light is lit solidly, audio output is muted.
- There are two approaches to using time compression to shrink a program:
 - A quick BUFFER+PLAY usage, so you can quickly insert content in the beginning or middle of a show
 - A more targeted usage where you enter in exact amounts you want to shrink by, then Set PLM to start the process.

When you start an operation the screen will look like this:

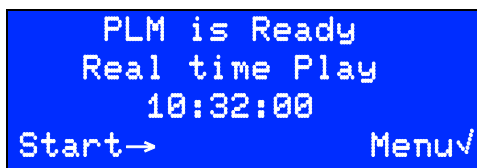

There is nothing in Delay memory.

The current time is 10:32. PLM can display time in 12 or 24 hour modes. Press the right arrow key → to start an operation, or Press the ✓ check mark to enter the configuration menus.



To quickly insert content...

BUFFER+PLAY provides a quick way of essentially pausing your main program, while you insert other content. For example, you could be in the middle of a network or pre-recorded program, but need to quickly get an emergency news bulletin on the air. With PLM, you simply need to listen for a place to pause the main program, press BUFFER

and start broadcasting your news update. Incoming signal is recorded to PLM's internal buffer, and the output is muted to prevent mistakenly sending that signal to air. With this quick method, you don't even need to know in advance how long the insertion will be. When the inserted extra message is complete, simply press PLAY. PLM will now return to playback of your original program where you left off, but you will now be playing faster than real-time. The LCD will display how much you've buffered, and how much time it will take to catch back up to real-time play.

You can record audio to the buffer at any time by pressing the BUFFER button. As PLM buffers audio, the button is lit. The display will change to this:

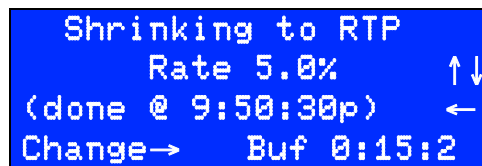

Upon play back, PLM will shrink until RTP (real-time play) is reached. The shrink rate can be adjusted using the up/down ↑↓ arrow keys. While buffering, the done@ time will count up. Use the ← key to view a countdown time. The Buffer counter display will increase while buffering.

When the spot or piece you are inserting finishes playing, press PLAY. The BUFFER button will go dark, and the PLAY button will light. Audio output will resume. The screen above will update:

- The buffer counter will update, counting down toward 0:00.
- You can use the up/down ↑↓ arrow keys to increase or decrease the rate of time compression.
- As you change the rate, the done @ and done in time displays will update. The larger the rate value, the sooner PLM will catch back up to real-time play.
- Use the ← key to toggle between the “done @” time and “done in” countdown timer.
- You can buffer up to 15:00 of audio in PLM. Once this limit is reached, PLAY will automatically start.
- You don't have to wait to catch back up to real-time (0:00) before you press Buffer/Play again. If you need to insert more audio before you are caught up from the last insertion, PLM will simply add on to the existing buffer.
- Once the buffer empties and real-time play is reached, the PLAY button will go dark, the start-up screen will display and you'll be ready for your next use with no need to press RESET.

Shrinking to a target

The quick BUFFER+PLAY method will probably suffice for most time compression operations, but in some cases, you may want shrink a program by an exact amount, pre-roll it into PLM in advance of its air time, and generally line things up to a target.

From the startup screen, Press the → Right arrow key to Start. You'll see the following screen, and the "Stretch or Shrink-by" value on the 3rd line will be flashing, indicating it is currently selected.

```

Input time: 60:00 →
Output time: 58:00 ←
Shrink by: 2:00 ↑↓
Cancel X          Set√
  
```

The → key will select the Input Time for adjustment.

The ← key will select the Output Time for adjustment.

The ↑↓ keys adjust the current selection; in this case, the Shrink-by time

Press the √ key to confirm values

Note that this setup screen will start with values used in the last operation. In cases where the last use of PLM was to Stretch a program, make sure you don't confuse the two modes. You should either:

- Use the down arrow key to drive the stretch-by value down to a shrink-by value. EG: as you reduce the value from "Stretch-by 1:00" and go below 0:00, the screen will update to say Shrink by and the number display will start counting up.
- Or, enter an Input time that is larger than the Output time. This will drive the value of the Shrink-by time.

Note the following:

- The Input time is the actual duration of the program you want to shrink.
- The Output time is the target size you want the program to be.
- The difference between the two is the Shrink-by time

Whenever you alter either Input or Output times, it will drive changes to the Shrink-by value. You can adjust any of these three values. Use the left ← and right → arrow keys to select which field you want to adjust: the flashing field indicates the current selection. As you adjust either the Input time or Output time, the Shrink-by time display will update. You can adjust the Shrink-by time directly: doing so will alter the Input time. Output time is anchored and will not change if you adjust the Shrink-by field, since this target program length is considered a fixed amount in any program hour.

Once you have entered your time values, press set √. The screen will update with this display. PLM is now ready to shrink a program.

```

Will Shrink 2:00
Rate 5.0%      ↑↓
(done @ 5:30:30p) ←
Change→ Buf 0:00:0
  
```

2:00 is the target amount to shrink by.

The ↑↓ keys adjust the rate of time expansion.

The ← key toggles display between clock time and countdown to completion. The → key takes you to the previous screen where you can adjust the Input/ Output times and Shrink-by value.

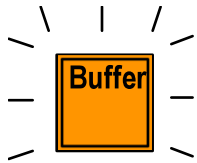

The BUFFER button will start flashing, prompting you to press it when you are ready. When you start playback of the program you want to shrink, press BUFFER simultaneously.

As buffering begins, the BUFFER button will light solidly and the display above will update to reflect your progress.

- The Will Shrink value and the Buffer value will flash until the target is reached.
- Once the Shrink-by target is reached, the BUFFER button will light solidly and the PLAY button will now start flashing, prompting you that PLM is ready to start compressed playback.
- The Will Shrink value and the Buffer value will stop flashing in the LCD, but the buffer value will continue to increase until you press PLAY.
- Once you press PLAY, the button will light solidly, and the BUFFER button will go dark. Compressed playback will start.
- You can change the rate of time compression using the ↑↓ keys either while buffering, or after playback has started. When shrinking audio, the higher the rate, the faster speech will sound and the sooner the target will be reached.
- As you adjust the rate, the time to completion is altered. Make sure you choose a rate that will finish your shrink operation on schedule.
- Press the ← key to toggle between viewing done @ and done in times. Done @ is the actual time¹ that the operation will complete, and done in is a countdown display indicating how much time the stretch will take.
- If you made a mistake entering the amount of time to shrink, you can make changes, even once shrinking has started. Press the → button to return to the previous screen where you can edit values. Confirm changes by pressing the Set/ button.
- You can pre-roll audio into PLM up to 15 minutes before it is ready to air, but remember that PLM will automatically go from Buffer to Play mode once the 15:00 buffer is full.

Once a shrink operation is complete, the LCD screen will update accordingly:

```
Shrinking 2:00
Rate 5.0%    ↑↓
(target reached) ←
Change→     Buf 0:10:0
```

2:00 is the target amount

The ↑↓ keys adjust the rate of time compression.

Once the target is reached, the ← key has no effect.

The → key takes you to the adjust screen where you can re-adjust the Input/ Output times. "Buffer" shows you are running a static 0:10 delay.

¹ For best results, make sure to set up network time protocol (NTP) so that PLM's clock stays accurate.

Upon reaching the target (shrinking 2:00 in our example) time compression will cease, audio play out will return to normal speed, and the PLAY button will stay lit.

At this point, PLM may be running a delay, depending on when you started playback. For instance, if you set a shrink operation to shrink 2:00 minutes, but you started playback after the buffer filled to 2:10, you would have a :10 second buffer remaining when the operation completed.

With this extra :10 in the buffer, PLM would now be running fixed a delay, so any incoming audio will take :10 seconds from the time it enters the unit to the time it plays out. PLM has no way of knowing what constitutes the end of a program, so it is important that operators enter an Input time that matches the actual length of the program being time compressed.

PLM will continue to run this :10 second delay and the PLAY button will stay lit until the operator determines the program has finished playing out and it is safe to end the session.

Completing a Shrink Session

To end a Shrink operation, press the red RESET button. Upon the first press, a confirmation screen will appear.

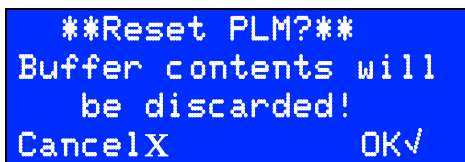

Warning screen when RESET is pending

X cancels, ✓ or pressing RESET again confirms and discards the buffer.



Pressing the RESET button a second time will confirm that you want to exit the session, discard any audio in the buffer, place the unit in real-time play mode, and return to the Start screen. If you pressed RESET by mistake, simply press the X button to cancel. The Reset confirmation screen will time out in 15 seconds if you do nothing.

Optimizing Compression Rates

Less is more when applying time compression or expansion. The lower the rate you run PLM at, the less noticeable any changes will be to the listener. For most audiences, 5% or less (5% = 3 minutes per hour, and is the factory default rate) will be imperceptible, even on music, and rates of 10% are generally fine for speech. More aggressive rates may be more noticeable to some listeners on certain program types, and very high compression rates may just sound unnaturally fast on some content. Optimizing rates to spread the time compression or expansion process out over as much available time as possible will yield the best results.

In our example of shrinking a 60:00 program by 2:00 to fit into a 58:00 length time slot, a compression rate of 3.5% would mean that the process would take 57:09 to complete. This rate is both subtle and safe, since it will insure that compression has completed by the time the last portion of program audio exits PLM's buffer at 58:00.

Conversely, a lower rate of say, 3.0% would take about 1:06:40 to complete. This rate would not be aggressive enough to shrink the incoming program in our example by 2:00 before the show's allotted time is up.

At the other end of the speed spectrum, a rate of 10% would finish shrinking 2:00 of audio in a quick 20:00 minutes. The first part of the show would sound substantially faster than the second half. In many cases, spreading the shrinking process out over a longer period is the best way to operate PLM. However, in some time compression cases, it may be advantageous to catch up to real time sooner than later, in the event that you need to do a quick time insertion later in the program.

There is a simple way to calculate how long it will take to stretch a program at various rates:

- Press Start, and enter Input / Output and shrink-by times.
- Press Set so that the BUFFER button is flashing. PLM is now ready to start buffering. But now, just leave it flashing so you can see how different rates will drive timer calculations
- You can now use the up/down arrow keys to vary the rate. The minimum rate is 1%. The Maximum rate is 20%. You can set a lower Maximum rate in the Control menu to prevent operators from running rates you consider too aggressive.
- Use the left arrow ← to toggle between the “done @” time and “done in” countdown meter. As you change the rate, these time displays will update, showing you how long or when your shrink operation will finish.

```
Will Shrink 2:00
      Rate 3.5%   ↑↓
(done in 0:57:09p) ←
Change→   Buf 2:18:0
```

*1:00 is the target amount to shrink by
The ↑↓ keys adjust the rate of time expansion.
The ← key toggles display between clock time and countdown to completion. The → key takes you to the previous screen where you can adjust the Input/ Output times and Shrink-by value.*

In our 2:00 example, a rate of 3.5% will finish shrinking our 60:00 program to 58:00 minutes well before it ends playing back.

As a general guide, all the following speed settings in this table will work to shrink a 60:00 long program into a 58:00 minute slot. Note that the 3.5% rate does not leave much margin; it will complete shrinking just a couple minutes before the show ends. Notching this setting down a mere .2% to 3.3% would require 1:00:37 to shrink the program, and would only reach the target after the show ended, resulting in a problem on air.

Speed setting	Minutes:seconds needed to shrink a 60:00 program by 2:00 to 58:00
3.5%	57:09
5%	40:00

7%	28:35
12%	16:41

Delay times, time manipulation, and speed selections

PLM uses advanced time manipulation algorithms that don't affect pitch and don't add harmonic distortion or frequency limitations. They also don't rely on deleting pauses, so they can be used on music as well as speech, and won't destroy your talents' delivery.

Lower speed numbers cause the least amount of tempo change, and are usually imperceptible. But they take longer to shrink a buffer to return to real-time, or build a delay while stretching a program.

Higher speed numbers will get you to your target more quickly, but might cause a noticeable speed change on fast-paced material. The highest numbers might also cause occasional doubling of fast consonants or drumbeats while stretching a program to make it longer.

Front Panel

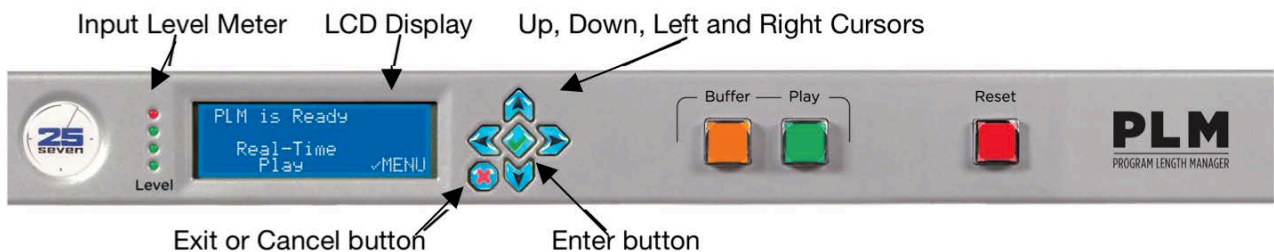

The Input Level Meter shows PLM's audio level on four LEDs. For highest quality, at least one should be flashing whenever there's audio.

The Cursor buttons let you navigate around the LCD display. In this manual, they're shown as ↑ ↓ ← and → for Up, Down, Left and Right.

The Enter button (shown as ✓ in this manual) is used to open menus and confirm choices. The Cancel button X exits the current menu without making any changes.

The BUFFER, PLAY, and RESET buttons are discussed starting on page 5.

PLM automatically goes into electrical bypass, connecting its XLR inputs directly to its outputs, when power is removed.

Details of the rear panel appear in the Installation section, page 31.

Detailed Operating Instructions

When PLM is first powered up, transport buttons will light. After about 10 seconds, the LCD will display this initialization screen for a few moments:

```
Welcome to
25 Seven Systems
PLM
Please wait...
```

Once the hardware is successfully initialized, the unit starts up with the following screen:

```
PLM is Ready
Realtime Play
10:32:00
Start> Menu√
```

There is nothing in Delay memory.

The current time is 10:32. PLM can display time in 12 or 24 hour modes. Press the right arrow key → to start an operation, or Press the check mark to enter the configuration menus.

This screen also appears after you press and confirm a Reset.

If you press the BUFFER button while the main screen is showing, PLM will start building a delay, and will mute audio output until you press PLAY. Use this simple mode (described earlier in this manual) as a quick “Pause/Play” method for quickly inserting extra content in the middle of a show.

Livewire users may see the following screen.

```
PLM waiting for
Audio stream...
Menu√
```

PLM must have valid Livewire channels selected to pass audio. Refer to the AXIA-Livewire section at the end of this manual for more specific information.

General menu procedures

A few elements are common to many of PLM’s screens:

- `Menu√` means press √ to see a deeper menu. See *PLM’s Menus*, below.
- `OK√` means press √ to apply a parameter change, and return to the next higher menu. But it won’t be saved permanently within PLM. See *Confirming Changes*, below.
- `CNCLX` means press X to return to the next higher menu without making any additional changes. If you’re on the Master menu, pressing X exits the menu system and

takes you to either the Main operating screen or the Confirmation screen (next section).

- ↓↑ Chg value means use ↓ or ↑ to change the value highlighted on this screen
- ← → Chg field appears when a screen has more than one value that can be changed. Use ← or → to select which value is changed by the ↓ or ↑ buttons. The active field will be flashing on PLM's screen.
- More↓ and More↑ mean use ↓ or ↑ to see more menu options in this category

Confirming Changes

If you've made any parameter changes while in the menu system, you'll see a Confirmation screen like this before you return to the Master menu¹:

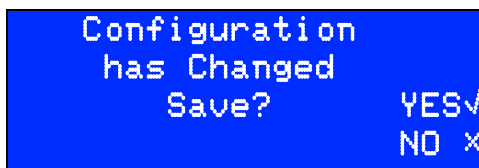

Press √ to permanently save these changes

Press X to erase these changes and restore PLM's former settings

If you don't press either button, the Confirmation screen times out after three minutes. Any changes you just made in the menu system are cancelled, and PLM returns to its normal operating screen.

PLM's Front Panel Menus

These menus can be activated from PLM's front panel, or via its secure Web interface. For this part of the manual we'll show the LCD versions.

If you're controlling PLM from a Web browser, most of the GUI versions of the menus will be virtually identical. The Web interface also includes extra configuration options that aren't available from the front panel. These start on page 25.

Master menu

If you press √ while `MENU√` is displayed, the screen will change to look like this. Here you can choose to adjust:

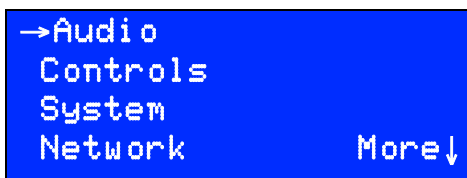

Press → to enter the Audio menu

...or use ↓ and ↑ to access other menus

"More↓ means keep pressing to see additional options. These are shown below.



"Press ↑↵ to see previous options (shown above).

¹ Depending on which menu you're in, you may need to press X a few times to see the Confirmation screen.

Audio menu

```
→Audio Input
Audio Output
Input Level
Output Gain
```

Select analog or digital inputs*

Select AES/EBU or SPDIF digital output. Analog output is always on*.

Adjust the analog input level to match your studio's "0 VU"

Adjust the output gain to match studio's "0 VU"

Audio menu options

- **Audio input** Choose Analog, digital AES/EBU, or digital SPDIF (all input formats are stereo). Only one of these formats is available at a time.
- **Digital out** Choose AES/EBU or SPDIF. This affects both the data format and the electrical specification of the digital audio output connector (page 32). The digital output is always active, even if you've chosen an analog input.
- **Input sensitivity** The LCD will look like this:

```
Input Sens.
+14dBu=0DBFS
↓↑ Chg Value      OK✓
L:-70 R:-70      CNCLX
```

Current value is +14 dBu: the absolute loudest analog signal PLM will see in your installation.

Press UP or DOWN to change the input sensitivity.

Current analog inputs equal -70 dBFS digital.

Select a value between +20dBu and -10dBu to result in fullscale within PLM and on the digital output.

The bottom line of the display shows current Left and Right internal levels in dBFS. This is the result of the incoming analog signal, adjusted by the second line of the LCD and sent to the analog-to-digital converter. Typically, these should read -12 for a +4 dBu lineup tone¹.

For most installations, where 0 VU = +4 dBu, we recommend setting the analog Input sensitivity to +14dBu=0dBFS.

- **Analog Output Level** Shown when analog or digital inputs are selected. The LCD will look like this:

```
Output Level
0DBFS=+14dBu
↓↑ Chg Value      OK✓
L:-70 R:-70      CNCLX
```

Current calibration is 0 dBFS within PLM will yield a +14 dBu analog output. This is equivalent to the "0 VU" = +4 dBu standard, with 10 dB of headroom.

Current Left and Right output levels in DBFS

Select a value between -10dBu and +20dBu to appear at the analog outputs, when PLM's internal digital signal level is 0 dBFS. This is usually set to match the Analog Input sensitivity, so our recommendation for most facilities would be 0dBFS=+14dBu.

¹ The +14 dBu sensitivity in the figure would make these meters read -10 dBFS with a standard +4 dBu line level test signal. In other words, the setting means a +14 dBu signal would read 0 dBFS—the maximum allowable digital signal—and standard line level is 10 dB less than that, or -10 dBFS.

However, you can use other settings if you want PLM to also create analog audio gain or loss. Note that during Bypass mode, any such gain or loss is also bypassed: the output equals the input.

The analog outputs are always active, even if a digital input has been selected.



Don't confuse dBu—an analog measurement—with digital dBFS!

Analog dBu is a comparison to an arbitrary voltage (.775 v), and signals can be much hotter. A console's output is typically +4 dBu (1.228 v) when the meter reads 0 VU, but that's for a sinewave test signal. Peaks in voice waveforms, in real-world broadcasting, can sometimes be considerably above that... even though properly-calibrated VU meters are too slow to register them. Analog is very forgiving of these momentary peaks.

However, in the digital world, 0 dBFS (decibels referred to Full Scale) is an absolute ceiling. Some devices distort horribly or crackle when an input attempts to pass this value. PLM handles overloads differently, applying serious limiting to gracefully protect your signal (and listeners).

If your facility uses the +4 dBu standard of modern broadcast equipment, our recommended setting of +14dBu= 0dBFS provides 10 dB of headroom for protection while still maintaining an 84 dB signal-to-noise ratio. With this setup, it's unlikely that PLM will ever go into distortion or audible limiting.

If you're dealing with heavily-processed feeds you can use a lower setting; for seriously dynamic performances it may need to be higher. PLM has 94 dB dynamic range at all settings, within 2 dB of the theoretical limit for 16-bit sound.

Controls menu

```
→Default Rate  
Maximum Rate
```

Controls menu options

- **Default rate** Use ↓ and ↑ to set the default time compression (shrink) and time expansion (stretch) rate. Choose between 1 and 20 percent. This rate setting represents a common value for both compression and expansion.
- **Maximum rate** Use ↓ and ↑ to set a rate limit for stretching or shrinking audio. A rate limit will prevent operators from driving time compression or expansion rates too aggressively. Choose a value between 5 and 20 percent.

System menu

```
→Brightness  
Contrast  
Time Zone  
Time/Date      More↓
```

Press DOWN to see more options

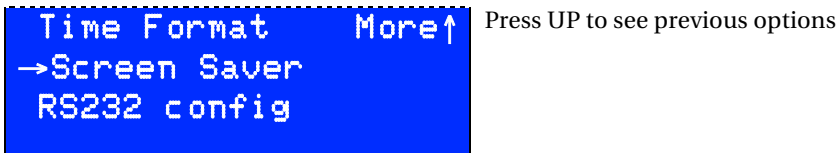

System menu options

- **Brightness** Select a value for the LCD display
- **Contrast** Select a value for the LCD display
- **Time Zone** Select a time zone for when Network Time Protocol (a feature that automatically sets PLM's internal clock, described on page 22) has been selected in the **Net** menu. Choose from the four named US time zones, with or without Daylight Savings Time, or any internationally used offset from Greenwich Mean Time.
- **Time/Date** Set the current time and date manually, when Network Time Protocol is not being used.

Why bother setting the clock? Because PLM's shrink and stretch displays predict when an operation will complete. If the clock is wrong, the predicted time of completion will be wrong too.

- **Time Format** Select 12 Hour (AM/PM) or 24 Hour ("Military time").
- **Screen Saver** Use ↓ and ↑ to set how many minutes of inactivity will pass before PLM's LCD display goes dark. Or choose **Never**, if you want the screen to remain lit at all times¹.
- **RS232 config** Use ↓ and ↑ to set the baud rate for the RS-232 serial connector on the rear panel. Choose standard values between 1200 and 115200 baud. The factory default is 9600.

Network menu^{2,3}

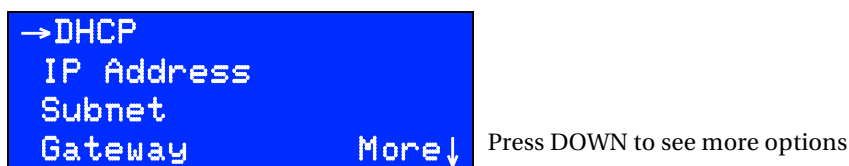

¹ Leaving the screen lit at all times can shorten the life of the LCD's backlight.

² While broadcast engineers are becoming more and more net-savvy, you may need to consult with your station's IT manager about appropriate settings for your data network.

³ We recommend you adjust these settings from PLM's front panel, rather than using its GUI from a remote network computer, so you don't accidentally change something that'll break the connection. Numeric IP addresses should only be set from the front panel.

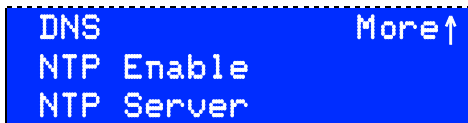

Press UP to see previous options

Network menu options

- **DHCP** Choose `enabled` or `disabled`.

Use `Enable` if your network router is set up for DHCP address assignment. When DHCP is enabled, your unit's IP address, Subnet, DNS Server, and Gateway are supplied by the router. `Enabled` is the factory default.

- Enabling and disabling DHCP, then pressing `DONE`, will ask your system's router to reset PLM's IP address. It may take a few moments before a new address is registered.
- Depending on your network's router, after you enable and confirm a change to DHCP, you may need to power cycle PLM to get an address.
- PLM responds to Pings across your network. You can use this to determine if an address is valid and the network is working properly.

Fields in the following menus "roll over" between their limits of 0 and 255. If the `0` is showing, press `↓` to jump to 255; if `255` is showing, press `↑` to jump to `0`.

- These first four menu options appear only if DHCP is `Disabled`. Otherwise, the information is supplied automatically by your router.
 - **IP Address** When manually setting network addresses, use `→` and `←` to change fields; `↓` or `↑` to set values.
 - **Subnet mask** In most cases, this should be set to `255.255.255.0`.
 - **DNS Server** DNS stands for "Domain Name Server". This number is supplied by your Internet Service Provider [ISP] or IT department. Just about every modern computer, including PLM, uses one of these servers to access the Internet.
 - **Gateway** The IP address of your LAN's Gateway system or router that connects PLM to the Internet, also supplied by your ISP or IT department. It's needed so PLM can connect to servers outside your local area network.
- **NTP** Enables or disables PLM's ability to update its time-of-day clock automatically from a Network Time Protocol server¹. If enabled, PLM's clock cannot be manually set.

¹ NTP works fastest if the system clock is already fairly close to the current time. We recommend you set the `Time/Date` and `Time Zone` manually (page 20) before enabling this feature.

- **NTP Server** Enter the IP address of the network time server. This menu item appears only if NTP is enabled.



About NTP

Network Time Protocol servers supply accurate time-of-day and other data over the Internet. PLM can use them to automatically set its internal clock. Your facility might also have its own NTP server.

NTP servers are often identified by a domain name—a familiar-sounding “.com” or “.gov” URL—rather than their numeric IP address. PLM requires numeric IP addresses.

You’ll find a list of US servers, with both their domain names and their IP addresses, at the National Institute of Standards and Technology’s website¹. International time server domain names are listed at www.ntp.org. Please respect the access policies listed by the server provider and IT department. PLM users should never select a Primary server for NTP updating; use Pool or Secondary servers instead.

The best way we have found to test whether NTP services are working is to manually offset your PLM clock by a couple of minutes, then enable NTP. If your network connections are working and your NTP address is valid, the system clock should quickly acquire the correct time.

GPIO Menu (General Purpose Input/Output)

```
→GPIO Enable
GPIO Inputs
GPIO Outputs
GPIO Test
```

This menu lets you program the parallel inputs and outputs for remote control.

- **GPIO Enable** Select **Enabled** to activate General Purpose Input / Output control, a parallel remote control mode accessed through the female DB-25 jack on the rear panel. Select **Disabled** if you have a remote connected to this jack but want to temporarily turn it off.

GPIO wiring details are covered on page 33.

PLM’s GPIO system doesn’t use noisy relays and won’t be tripped by normal static impulses. You can leave it **Enabled** even if there is no remote control plugged in.

- **GPIO Inputs and GPIO Outputs**

¹ The list itself is currently at <http://tf.nist.gov/tf-cgi/servers.cgi>. If NIST has moved it from that location, use the search box on their home page, www.nist.gov, to find “Internet Time Service”.

The GPIO system has to be configured to determine which PLM functions appear at which pins on the rear-panel DB-25 jack. To configure GPIO, the arrow keys to select `Ins` or `Outs` and press `√`. The LCD will look like this:

```
GPIO Inputs:
In1=Dump
↑↓ Chg Value      OK√
←→ Chg Field     CNCLx
```

Each of the 8 Inputs or outputs (e.g., `In1`, `In2`, `Out1`, `Out2`, etc) can be assigned to a PLM function, as listed on the following chart. The same function can be assigned to multiple inputs or outputs, if you require two or more isolated circuits for it.

GPIO FUNCTION	INPUT SETTING*	OUTPUT SETTING†
Nothing Assigned	None	None
Play button	Play	PlayTrig
Buffer button	Buffer	BufferTrig
Reset button	Reset	ResetTrig
Cue point #1 [¶]	Cue1	Cue1
Cue point #2 [¶]	Cue2	Cue2
...etc (up to 8 Cue points)	<i>etc</i>	<i>etc</i>
Flag point #1 [¶]	Flag1	Flag2
Flag point #2 [¶]	Flag2	Flag2
...etc (up to 8 Flag points)	<i>etc</i>	<i>etc</i>
Shrink or Stretch: pulse on complete		DoneTrig
Buffer amount: pulse on Empty		EmptyTrig
Play: mimic lamp state		PlayLamp
Buffer: mimic lamp state		BufferLamp
Reset: mimic lamp state		ResetLamp
Playing in progress		Playing
Buffering in progress		Buffering
Time compression/expansion active		Processing
Shrink or Stretch process finished		Done
Buffer currently empty		Empty

Important notes about the table:

* — Where an input function has the same name as a PLM front-panel button, the input behaves just like that button.

- For example, a momentary pulse on a GPIO `Buffer` input will start buffering audio, just as if you'd tapped the `BUFFER` button.

† — There are multiple outputs for some PLM functions:

If an output setting ends with `Trig`, PLM generates a single 250 ms output pulse when that state is reached. This can be handy for interfacing with automation systems.

If an output setting ends with `Lamp`, PLM's GPIO output mimics the front panel button's lamp. It stays low when the lamp is on, high when the lamp is off, and cycles when the lamp is flashing. This can be handy for building custom remotes for talent and producers.

`Playing`, `Buffering`, `Processing`, `Done` and `Empty` indicate PLM's current operational state, and are held low for as long as these states exist.

¶ — “Cue” and “Flag” settings mark the audio as it comes into PLM. These marks are locked to specific audio samples, so they be triggered on output at appropriate places in the program material. The marks stay accurate, no matter how much time manipulation or delay is being applied.

- **Cue** marks generate a 250 ms trigger when they're reached. This can be handy when interfacing with automation systems.
- For example, if the network provides a contact closure when it's time for a local break, connect it to an input that has `Cue1` assigned. No matter how much delay is applied, PLM will generate a `Cue1` output when that sample is reached... which you can use to trigger other equipment to play the break.
- **Flag** marks record a continuous logic input. Their output reflects that logic state when the appropriate audio sample reaches PLM's output.
- For example, you can use a Flag to activate a skimmer or logging recorder. Connect a mic's tally signal to the input, and use its output to keep the recorder on whenever the mic is on the air... regardless of how much delay is in use.

GPIO TEST

The GPIO test screen is a time saving utility that lets you verify that GPIO connections and external remotes are properly wired. `Ins` change from 0 to 1 as you test fire remote GPIO inputs. `Outs` allow you to test fire PLM's GPIO outputs, for example, if you want to make sure a tally lamp is working on output 5.

```
12345678
Ins: 11111111
Outs: 00000000
↓↑←→Change  CNCLX
```

These change from 0 to 1 while PLM is receiving a trigger on the DB-25 input (1-8) identified in the line above.

Use LEFT and RIGHT to select an output. Then use UP or DOWN to change that output's state between 1 (on) and 0 (off)

When you leave the GPIO test screen, the DB-25 outputs are all reset to 0.

Information

Choosing this from the Master menu gives you a summary of PLM's current Audio, Network, and Time/Date settings; NTP status; network MAC address, and internal temperature¹. It also provides the unit's unique software module number, and the current version numbers of its front panel firmware and system software. You'll need this information if you call 25-Seven for support.

Graphical User Interface and Browser Control

You can access PLM from a Web browser in any computer on the data network, if you have the proper password.

Logging in to PLM from a Connected Computer

- Launch any standard Web browser, on any Windows, Macintosh, or Linux computer on your network².
- Set the browser to `http://nnn.nn.n.nn`, where the n's are PLM's IP address. You can read that address from the **Information** menu on PLM's front panel.
- When it connects, you'll be asked for a User Name and Password
 - Use `plmweb` as the user name, and `plmwebBnnn` as the password (where Bnnn is the software module's unique identification code, which you can find on the Information screen). `plmwebBnnn` is the factory default password. You can change or view your password from the front panel in the System / Password menu (page 20). Passwords are case sensitive.

If it doesn't connect, you may have a problem with your network connections, the version of Flash installed in your browser, or your system's configuration³.

After successfully connecting, PLM will draw its Graphical User Interface on your Browser's screen.

Selecting GUI Pages

PLM's GUI is organized by pages, to make it easier for you to find particular functions.

¹ See note about temperature on page 30.

² Web-based control relies on Adobe Flash being installed in your browser. Flash communicates with PD over port 5444. If this port is blocked by your firewall, Web-based control will not function.

³ This may be a setup issue in PLM's menus or your local computer, a network wiring or configuration problem, or even something as simple as entering the IP address wrong in your browser. PLM responds to Ping commands as an aid for debugging.

You'll see two tabs across the top of your browser's screen:



Click one of the tabs to select which page you'd like to work on.

The top line always displays the name of this specific PLM (in this case, "PLM1"). You can change this name by using the Configuration page.

Front Panel GUI Page

After connecting and authentication, your browser will change to look like this:

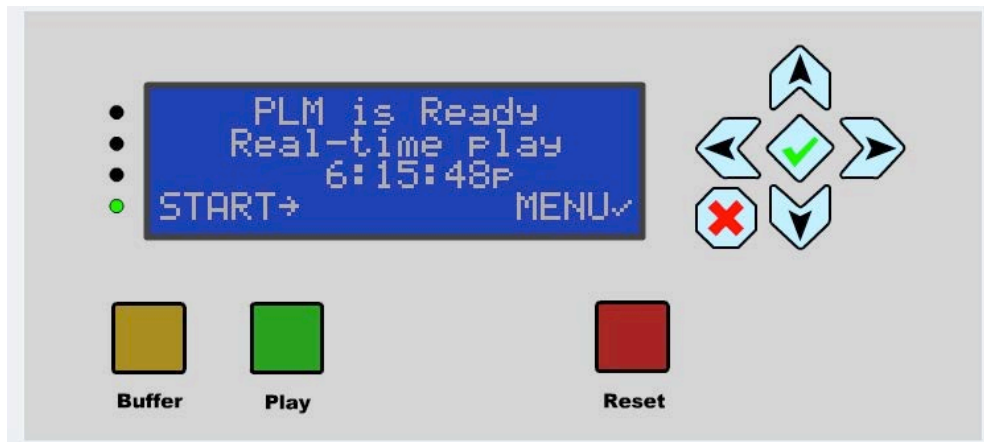

You can also access this page by clicking the **FRONT PANEL** tab on the top of the GUI.

This page is fully interactive. On-screen buttons can be clicked with your mouse; the text displays whatever is on PLM's LCD at the time; LEDs and buttons flash as they would on the front panel.

You can operate PLM from this page, the same way you would from its hardware front panel, or use the pane to monitor LEDs and buttons.

- When using the GUI to control a PLM in another studio, always check to make sure the unit is not currently in use! Remember that a PLM in Ready mode may actually be feeding real time audio to your program bus.
- The GUI may be operated over a LAN or WAN. Use over the open Internet is possible, but we recommend you keep PLM behind a VPN.

You can also use this page to configure PLM using the menu system. But it's much faster to use the Configuration page.

Configuration page

Click on the **CONFIGURATION** tab at the top of the GUI, and your browser changes to look like this:

The screenshot displays the configuration interface for a PLM (Program Length Manager). It is organized into several sections:

- Identification:** PLM name: Module number: 000
- Control:** Initial compression/expansion: % Max compression/expansion: %
- Hardware GPIO:** Hardware GPIO: Enabled. Inputs: In 1 (Play), In 2 (Buffer), In 3 (Reset), In 4 (Cue1), In 5 (Cue2), In 6 (Cue3), In 7 (Cue4), In 8 (Cue5). Outputs: Out 1 (PlayTrig), Out 2 (BufferTrig), Out 3 (ResetTrig), Out 4 (DoneTrig), Out 5 (EmptyTrig), Out 6 (PlayLamp), Out 7 (BufferLamp), Out 8 (ResetLamp).
- Other I/O:** Network port 5443: Enabled. Serial port rate:
- Front Panel:** Screen saver: Brightness: Contrast:
- Save Changes:**
- Version Information:** PLM version: 1.0 LSP version: 2.4 AIO version: 3.10.03.1 WEB version: 2.25b.4 IOB version: 1.1.4 UTIL version: 1.2

Changes that you enter on this page don't take effect until you press the Save button.

- If someone enters changes at PLM's front panel while this GUI is open, the changes aren't reflected on your networked computer until you use your browser's Refresh feature. To avoid confusion, don't try to make configuration changes on both the GUI and PLM's front panel at the same time.

Identification shows the hardware and software of this PLM. You can set a PLMname for easy identification of this hardware. If you have more than one PLM, make sure they have different names.

Control and Hardware GPIO let you view and change settings that are on the matching menus of PLM's front panel. Since the GUI has drop-down menu selections, you'll probably find this faster than navigating through the front panel.

Other I/O allows you to enable serial commands over network port 5443, and set the baud rate for rear panel RS-232 serial lines.

Front Panel mimics the front panel menu settings on PLM's LCD.

Save Changes The Save button changes PLM's internal settings to match whatever you've entered on this page. **Revert** cancels your recent entries, replacing them with whatever had been previously set in PLM.

- Whenever you make changes on the configuration page, the title of that selection appears in **bold** to indicate a change is pending.
- When you successfully Save those changes, the selection title reverts to normal text.
- If you type an invalid value or setting, that field appears in **red** to indicate an error.

Version Information may be helpful during factory support calls.

Remote control

PLM supports multiple different remote control types, for maximum flexibility. All can be used simultaneously.

Parallel (GPIO or "Contact Closure") Control

There are eight inputs and eight outputs for remote control on a rear panel female DB-25 connector. Each can be assigned to PLM functions through a configuration screen, described on page 22. Multiple inputs or outputs can be assigned to the same function if you need isolated circuits. Inputs and outputs are opto-isolated, active low; wiring details are on page 33.

Serial Control

PLM includes a built-in control language, which can be accessed via standard serial connections or Ethernet.

Standard serial connection

Data and control lines appear on a male DB-25 connector in both RS-232 and RS-485 formats. Electrical specs and pinouts are on page 35.

The default communication settings are 9600 baud, no parity, 8 bits, 1 stop bit, no flow control (usually referred to as *9600N81*). Other settings can be chosen by the user; see pages 20 and 27).

Ethernet connection

Alternatively, serial commands may be sent over network port 5443. To enable this, check the box on the **CONFIGURATION** page of the Web interface (page 27).

Serial language structure

PLM's serial remote control language is designed to be easily implemented from any terminal program, macros in most automation systems, or computer programming language. Requests and responses are standard ASCII characters, based on plain English, using familiar PLM "front panel" designations whenever possible.

Requests, or messages from the controller to PLM, consist of a number of words, followed by a Line Feed character¹ <LF>. Messages are case-sensitive.

Responses, or messages from PLM to the controller, usually consist of a single Result character followed by <LF>. The Result character may be:

- ! Indicates command has been received and acted upon
- ? Indicates command isn't understood, or can't be acted upon

Request syntax

Requests consist of a *command* (something for PLM to do), usually followed by *arguments* (what it should act on), and then the <LF>.

Commands include:

- down Start the event described by <argument>
- up End the event described by <argument>
- trigger Momentary activation of <argument>, same as tapping a button².
- help Returns hints about PLM's serial language

Arguments include:

Buffer, Play, Reset, Cue1 *through* Cue8, Flag1 *through* Flag8

Arguments act the same as the identically-named GPIO inputs, which are described starting on page 22.

Examples

Note that requests are case sensitive.

REMOTE REQUEST	PLM RESPONSE	NOTES
down Buffer<LF>	!<LF>	<i>PLM starts buffering audio</i>
up Play<LF>	!<LF>	<i>PLM releases the Play button</i>
trigger Re- set<LF>	!<LF>	<i>PLM starts a Reset event</i>
help<LF>	!down	<i>* See note below</i>

¹ ASCII 10 (decimal) or OX0A (hex). Note that Carriage Return (ASCII 13) is ignored by the system.

² trigger <argument> <LF> works the same as sending down <argument> <LF> UP <same argument> <LF>.

	up(<i>etc</i>)<LF>	
help down<LF>	! (<i>text</i>)<LF>	* See note below
dump it!<LF>	?<LF>	<i>Unknown command</i>

* — Help does not require an <argument>.

- If you send help<LF> by itself, it returns a list of valid commands.
- If you specify any command as the argument, it returns a brief explanation along with a list the command's arguments.
- For example, if you send help down<LF>, PLM replies
- !down: send Press signal for one or more space-separated events (None Buffer Play Reset Bypass Cue1 ...etc to... Flag8)

Web Browser based Control

An RJ-45 jack on the rear panel lets you connect PLM to your local area network via 10/100-BaseT Ethernet. PLM includes an internal password-protected Web server; properly-configured browsers on the network can log in for an on-screen emulation of PLM's front panel, along with additional functions that are only available with the password. Complete details start on page 25.

This same network connection port can be used to automatically update PLM's internal time-of-day clock using NTP.

Installation

PLM fits a standard 19" equipment rack, 1 unit high by 12" deep (allow additional depth for the connectors).

PLM's information menu (page 25) shows the hardware's internal temperature. While PLM doesn't generate much heat, we recommend at least one unit of blank or perforated panel separating it from any heat-generating device mounted below it. Do not block the fan or intake vent on the rear of the unit.

- As a general guideline, PLM should run within 20° (Fahrenheit) of ambient room temperature. We recommend that you check operating temperature occasionally.
- PLM's cooling fan is its only moving part, and it must move freely to keep PLM in normal operating range. If heat readings appear high, check the fan and intake vent immediately.

The internal power supply will self-adapt to any voltage between 100 – 240 v 50/60 Hz. It consumes 1.8 A maximum; typical draw is about 32 watt @ 120VAC.

We recommend that PLM be connected to a UPS (uninterruptible power supply), to prevent loss of audio in case of a power disruption. This is good advice for any mission-critical electrical device.

PLM can be inserted anywhere in an analog or digital signal path where you want to control program timing and duration. But for maximum flexibility and efficiency, we recommend using a routing switcher: have every source you'd want to time-control (such as remotes and network feeds) connected to an input, and at least one output for PLM and one for monitoring. Connect PLM's output directly to a console input channel, or back through another router input. Obviously, you need stereo connections at the router if you intend to use PLM on stereo signals.

If your station uses Arbitron PPM, place our unit *before* their encoder in the signal path. This will ensure PPM encoding is not affected when time compression or expansion builds or exits delays.

Rear Panel

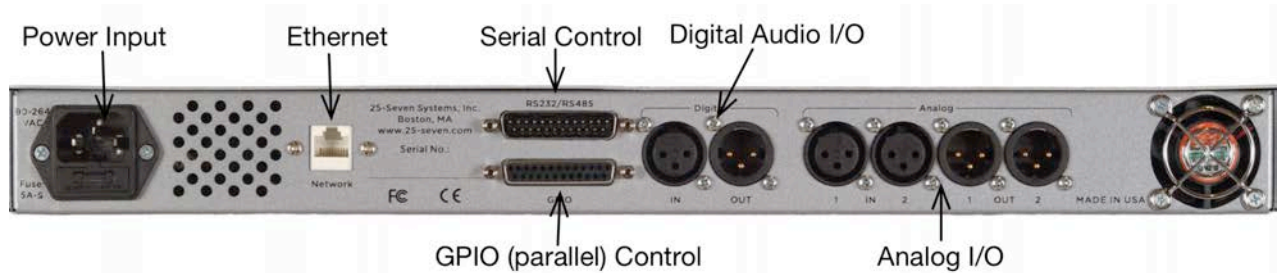

Power Input

Standard IEC configuration self-adapts to any voltage between 100 – 240 volts AC, 50 or 60 Hz.

Ethernet

Connect to a standard 10/100Base-T network connection. All PLM models use this port for remote control via web browser, serial remote control over IP, and synchronization to a network time server. If connected to the Internet, it should be behind a hardware firewall.

Livewire users of PLM should connect to this port for audio and GPIO over IP on Axia networks. See the Axia/Livewire section at the end of this manual for more information.

Digital Input

When set to AES/EBU via the **Audio** menu, this input conforms to IEC 958 Professional (5v p-p, 110Ω balanced) on XLR connectors.

When set to s/pdif, the voltage and impedance switches to IEC 958 Consumer (.5v p-p, 75Ω unbalanced): connect signal to pin 2 and shield to pins 1 and 3.

Warning: XLR-equipped PLMs will lock to any valid 44.1 kHz, or 48 kHz signal at this connector, even if you've selected analog for the audio input. This lets you keep the digital output compatible with other equipment. But because of this feature, both the analog and digital outputs can be disrupted if PLM sees an intermittent or weak digital input signal. **Do not connect, remove, or change a digital input signal while PLM is on the air.**

Under extreme circumstances, an intermittent digital input can cause erratic audio behavior. If this happens, power-cycle the PLM.

Digital Output

When set to AES/EBU via the **Audio** menu, this output conforms to IEC 958 Professional (5v p-p, 110 Ω balanced) on XLR connectors. Output is 16-bit PCM linear.

When set to s/pdif, the voltage and impedance switches to IEC 958 Consumer (.5v p-p, 75 Ω unbalanced): connect signal to pin 2 and shield to pin 3 only. Do not connect pin 1 for s/pdif operation.

This digital output is always active on XLR-equipped PLMs, so you can use PLM as the converter if you have to handle an analog signal in a digital plant.

If there is no signal on the digital input jack, PLM provides its own low-jitter clock at a 44.1 kHz sample rate. When there is a valid 44.1 or 48 kHz signal at the digital input jack—even if analog inputs are selected—the internal clock and digital output are locked to it. Use this feature to make sure PLM's output works smoothly with your routers and other equipment. But see the warning about digital clocking above.

Analog Inputs

Information about input and output levels is on page 18. Unbalanced operation is not recommended.

These are electronically balanced XLR female, pin 2 hot, with a load of 20k Ω : this makes it compatible with all modern electronically-balanced outputs. If fed from a transformer-balanced output, we recommend bridging a 680 Ω resistor between pins 2 and 3.

Analog Outputs

These are electronically balanced XLR male, pin 2 hot, designed to feed a load of 600 Ω or greater.

PLM uses advanced algorithms to process signals in true stereo, with no smearing or variation in the stereo field during time compression. So while the analog outputs (and analog inputs) are labeled CH1 and CH2 on the back panel, we assume you'll be using them for the left and right channels of a stereo pair and that's how we've written this documentation.

However, you can also use PLM for dual, identical processing of two mono signals. There's no cross-talk.

Bypass Relays

Analog and digital XLR inputs and outputs are wired to bypass relays. In the event of a power failure, incoming audio is connected directly to the outputs. PLM powers up in bypass, then automatically connects after it successfully boots up.

GPIO

Eight parallel control inputs and eight parallel control outputs appear on the female DB-25 connector, with pinouts detailed below. Input and output functions are assigned through the GPIO menu.

Inputs and outputs are opto-isolated for easy interface to other equipment. A +5v supply and ground are also brought out to the DB-25 for simple remote controls using pushbuttons and LED status readouts.

The +5v supply can carry 200 mA, more than adequate for 8 LEDs and 8 logic inputs. It is protected by an internal, self-resetting thermal circuit breaker.

Basic remote control:

- 1) Use the connections shown on the left side of the schematic below. At the DB-25, jump pin 13 (input common) to pin 8 (+5v).
- 2) Connect one side of an SPST NO pushbutton to pin 20 (ground); connect the other side to pin 25 (Input 1).
- 3) Add up to 7 more pushbuttons as needed, connecting one side of all to pin 13 as common, and connecting their other sides to the individual inputs in the chart below.

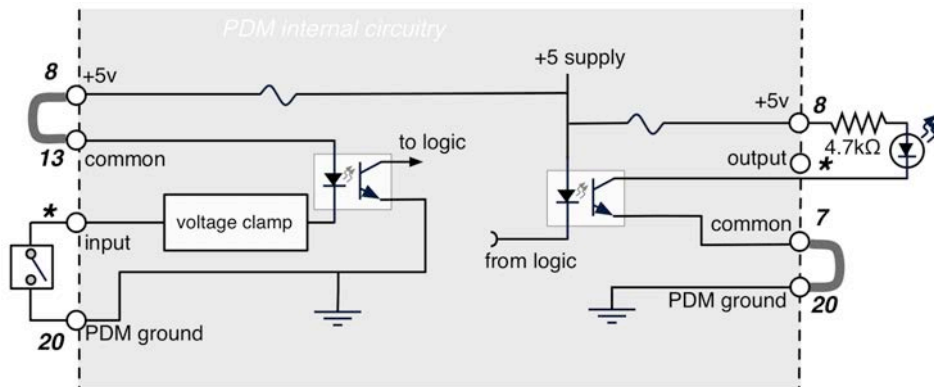

Typical PLM remote input (left) and output (right) circuits. Use the jumpers shown in gray for simple pushbutton / LED remote. Or use just the opto-isolator connections without pins 8 and 20 for interface to other equipment. DB-25 pinouts shown in bold. * indicates individual DB-25 pins for separate GPIO inputs and outputs; see chart below.

Basic remote readout

- 1) Use the connections shown on the right side of the schematic. At the DB-25, connect pin 7 (output common) to pin 20 (PLM ground).
- 2) Connect a 4.7 k Ω 1/4 watt resistor between pin 8 (+5 V) and the anode or + lead of an LED; connect the cathode or – lead of the LED to pin 19 (output 1).
- 3) Add up to 7 more resistor-and-LED combinations as needed, using pin 8 as the common voltage supply and connecting the LEDs cathodes to individual outputs in the chart below.

Connecting to external logic or relay circuits:

PLM's GPIO inputs and outputs are isolated from its power supply and ground, and can be connected to external logic circuits or the power supplies in remote equipment:

- Inputs require at least 6 mA flowing from the input common (pin 1) and the individual input circuit pin.
- Outputs can carry up to 100 mA, up to 30 V DC, between the individual output circuit pin and output common (pin 7).
- Outputs may conduct for a few seconds during power-up, as part of a self-test routine. Be aware of this if you are restarting PLM while the GPIO is connected to other equipment.

GPIO Pinouts

PIN	SIGNAL	PIN	SIGNAL
1	NC	14	NC
2	Ground	15	NC
3	Output 8	16	Output 7
4	Output 6	17	Output 5
5	Output 4	18	Output 3
6	Output 2	19	Output 1
7	Output Common	20	Ground
8	+5 VDC	21	NC
9	Input 8	22	Input 7
10	Input 6	23	Input 5
11	Input 4	24	Input 3
12	Input 2	25	Input 1
13	Input Common	NC — No internal connection	

Serial Port

RS-232

The RS-232 pins are configured as a computer DTE port, similar to the Comm 1 jack on desktop computers.

If you want to control it from a computer or dumb terminal, you'll need a DB-25 null modem or a cable that reverses pins 2 and 3 (data), pins 4 and 5 (flow control).

RS-485

There are also two independent RS-485 differential data lines on this connector. Each is independently controlled and programmable as input, output, or bi-directional. *At this writing, RS-485 features are not implemented in PLM.*

Serial Pinouts

PIN	SIGNAL	
1	NC	
2	RS-232 TX	<i>Output from PLM</i>
3	RS-232 RX	<i>Input to PLM</i>
4	RS-232 RTS	<i>Do not use</i>
5	RS-232 CTS	<i>Do not use</i>
6	No Internal Connection	
7	Ground	
8	RS-485 Port 1 +	<i>Differential pair. Bi-directional.</i>
9	RS-485 Port 1 -	
10	No Internal Connection	
11	RS-485 Port 2 +	<i>Differential pair. Bi-directional.</i>
12	RS-485 Port 2 -	
13 - 25	No Internal Connection	

Axia / Livewire setup

Introduction

PLM's optional Livewire version lets you connect your Program Length Manager directly to a Livewire network. Once configured, you can:

- Feed PLM with any signal available on your system
- Send its full-quality output to any available input (or multiple inputs at the same time)

- Control PLM directly from selected Axia consoles
- access PLM's GPIO system directly within a console, or at standalone nodes anywhere on the network.

All this is carried over a single Ethernet cable, from PLM's back panel to the closest Livewire network switch. No additional PLM wiring is needed; in fact, Axia-equipped PLMs don't even have active analog or AES/EBU audio ports.

All controls, and most of the menus, are identical to PLM's front panel. Operators won't have to learn anything new. Installation and setup is almost the same, with a few important exceptions.

For that reason, read the rest of this manual first. Then use this section to understand Livewire-specific setups.

If you have an analog | AES/EBU version of PLM and wish to convert it to run as a Live-wire device, please contact the factory.

Network Setup

Since PLM-Livewire uses network connections instead of standard analog or digital audio wiring, it won't operate until it's been properly configured for your network.

PLM's output audio is broadcast to the network as a single **Livewire Source Channel**, identified by a number between 1 and 32,767. This number should be unique on your network, and not be assigned to any other source channel.

PLM's input is fed by specifying a **Livewire Destination Channel** number. This is the Source Channel number of some other device on the network. It's often the output of a console, but it can be a network or remote, or any other signal source.

PLM's Livewire GPIO system provides multiple sets of inputs and outputs, in four groups of five i/o each. Each group is assigned a unique address.

- Any of the 20 inputs can be assigned any Input function from PLM's GPIO list (page 23). The same function may be set to trigger from multiple inputs.
- Any of the 20 outputs can carry any Output state from the GPIO list. A state may be assigned to multiple outputs.
- Inputs and outputs don't have matching functions (that is, from the same row on the list), or match their assignment in other groups. You are free to assign them any way you want.
- PLM's hardware GPIO is independent of Livewire. You can assign totally different functions from PLM's front panel (page 22).

If you are controlling your network with **Pathfinder™** routing and control software, you have to register PLM in Pathfinder's configuration controls. If Pathfinder doesn't know PLM is on the network, you won't be able to use that software to route its audio or GPIO.

Master menu

If you press \checkmark while `MENU` is displayed, the screen will change to look like this. Livewire configured PLM's replace the "Audio" menu with an "Axia" menu. Here you can choose to adjust:

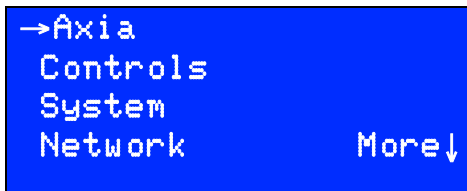

Press \rightarrow to enter the Axia menu

...or use \downarrow and \uparrow to access other menus

"More \downarrow " means keep pressing to see additional options. These are shown below.



"Press \uparrow to see previous options (shown above).

Axia Network Addresses

For Livewire to work, your PLM must have an IP address, and audio and GPIO channels have to be specified.

- 1) Press `MENU` and then `NET` to open the Network menu (page 20).
- 2) Axia uses static addresses for IP audio networks, so make sure `DHCP` is `Disabled`.
- 3) Manually set a valid `IP Address` and `Subnet Mask` according to the instructions on page 21. You may need to contact your network administrator or Axia instructions for specific information. Save the changes, and power cycle PLM so they get applied.

Once you've done this setup, view the `INFORMATION` page to verify PLM's IP address. Then you can check the connection by `Pinging`¹ that address from another computer on your network.

If you want to connect PLM to both an Axia system and a distant NTP server (page 22), you'll need to custom-configure your router. Contact your system administrator.

Livewire Audio Channels





25-Seven Systems follows Livewire conventions for *source* and *destination*. These channels may only be set from PLM's front panel LCD interface.

Open the `Network` menu on a Livewire-equipped PLM, and select the `Axia` menu choice. You'll see a screen like this:

¹ "Ping" is a network diagnostic tool provided with almost all computers.

```
➤ Axia Src Ch.  
Axia Dest Ch.
```

This screen lets you select Source or Destination channel menus.



Use  or  buttons to select which menu you want. Confirm your choice with  or press  to cancel.



The input to your PLM must be some other audio stream on the network, such as a network feed or the main output of a talk studio console. We call PLM the *destination*¹ for this signal, identified by the Axia channel number of the device broadcasting it.

Select Axia Dest. Ch from the Axia menu. The LCD will look like this:

```
Axia Dest.Channel:  
Pgm2@ LivewireStudio  
00120 OK✓  
←→↑↓Chg value CNCLX
```

This screen lets you set the Livewire Destination channel. As you scroll through channel numbers, this line shows the name of each signal available on the Axia network

Use  or  buttons to increment;  or  to jump by 100's.

Confirm your choice with  or press  to cancel.

- Remember: on the Axia Dest screen, you decide which signal this PLM is the *destination* for. Enter the channel number of *some other source* on the network. PLM will treat that source as its input.

Once you've set an address in this screen, PLM checks the network and makes sure the address is valid.

- If that address isn't valid, the front panel AUDIO LEDs remain amber.
- If the address is valid but the source isn't passing audio, the LEDs go dark.
- If there is a valid a valid audio signal, the LEDs light green to indicate its level.
- You can also check the signal flow by putting PLM in real-time play, feeding it a signal, and listening to PLM's Source Address on any Axia control surface or other monitor point.

Your PLM's output must be designated a *source*² before other devices on the network can listen to it. Assign it a channel number in the Axia Source screen. Other devices will be able to hear PLM's output by using this channel number as an assigned Destination signal.

¹ It may seem counter-intuitive to set up PLM's input with a "Destination" channel. We did this to be consistent with other Axia equipment.

² Again: we've followed Axia's standard for signal names, to keep setup as simple as possible.

Select Axia Src Ch. from the Axia menu. The LCD will look like this:

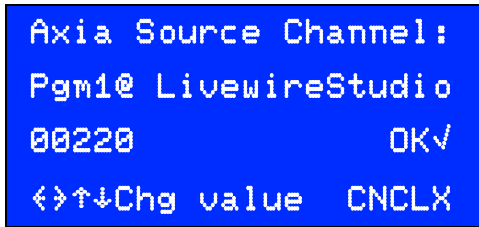

This screen lets you set the Livewire Source channel.

As you scroll through channel numbers, this line shows the name of each device available on the Axia network

Use or buttons to change channel numbers by single digits.

Use or to jump by 100's.

Confirm your choice with or press to cancel.

Livewire GPIO

Livewire GPIO

PLM-Axia units support the parallel DB-25 GPIO interface (page 22).

They also provide up to 20 additional inputs and 20 additional outputs of Livewire IP-based GPIO, with separate function choices for each.

The Livewire GPIO is configured using PLM's Graphical User Interface from a networked computer. Livewire GPIO may not be configured from the front panel.

Log into the GUI (page 25) and click the **CONFIGURATION** tab. In addition to the functions described on page 27, you'll see selections like these:

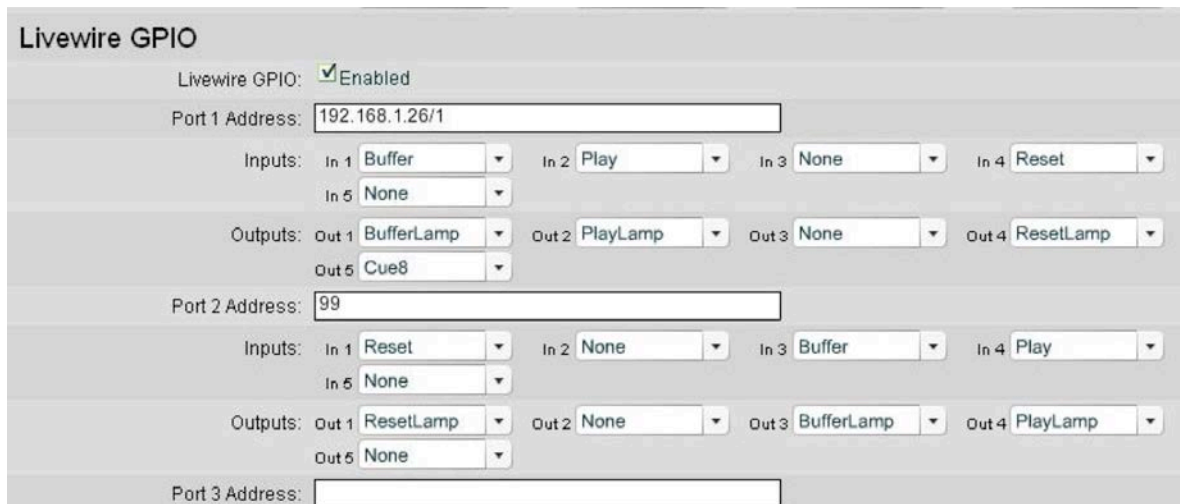

Ports 3 and 4 (not shown) offer the same drop-down menus as Ports 1 and 2.

PLM provides four Livewire ports with five lines each of user-selected input and output control.

- Each port's section contains a Port Address entry line. Type the address of a Livewire device you want PLM to communicate with. Devices are typically Element consoles with a Delay control or other remote section, or Axia General Purpose Input/Output Nodes.
- Input and Output selections for PLM Livewire GPIO are the same as for the PLM's Hardware GPIO. See page 22 for a complete list.

Element consoles

When communicating with an Element Console, enter the channel number that console communicates on. In the screen shot, PLM Port Address 2 is set to communicate with an Element Console on channel 99.

Other Livewire equipment

PLM can also communication with other equipment, such as a GPIO Node. From a PLM GUI on a network computer, enter a Port address. It should take the form of the IP address of the Node, a slash, and the port number of the device connected to the Node that you want to communication with (typically, 1 through 8).

In our screen shot example, PLM Port Address 1 is set to communicate with the device on port 1 of a GPIO Node at 192.168.1.26.

Troubleshooting

During startup, PLM's LCD will look like this for a moment:

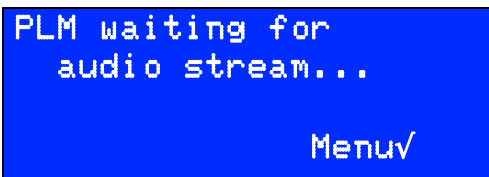

This means that ATM is logging on to the Livewire network.

Use √ to access the configuration menu

The screen will go away after PLM has successfully logged onto the Livewire network. Once it is gone, PLM's LED level meter should switch from yellow to green. You should see the meter bounce when IP audio is being properly sent to PLM.

If the `Audio stream` message remains up for several minutes after you start PLM, check the following:

- Does the INFO screen show a valid IP address?
 - Remember, Axia uses Static IP addresses assigned by the user, not DHCP addresses automatically provided by the router. If your PLM is set for DHCP, follow the instructions on page 37.
- If the address is valid, can you Ping this address from another machine on the same network segment?
 - If not, check network connections, cables, and switches.
 - Are you using the correct Network Mask? Some Livewire networks may be configured on a class B Subnet. Try changing the Network Mask setting to 255.255.0.0
- Is PLM as a destination (`Axia Dest Ch`) set to a valid *source channel number* for some other device on your Livewire network? If it isn't, PLM's LEDs will be amber and the `Waiting for Audio Stream` message will remain.
- Does Pathfinder know PLM is on the network? For some system configurations, you may need to register PLM as a device before any channels can be routed to/from it.

Once you're sure audio is being sent to PLM, the unit will start in Real-Time Play mode. Now you should be able to monitor PLM at its Source address (as set in the **Axia Source** screen), from other devices on the Axia network. Verify meter and monitor levels to and from the PLM at your Livewire node or control surface.

Avoiding Trouble

PLM's link to the network should never be disconnected while the unit is in normal operation. Loss of network connection while the unit is operating will result in a loss of audio, and **Waiting for Audio stream** gets displayed on the LCD.

Once the network connection is restored, PLM will return to Real-Time Play, and you can continue normal operations.

Software Updates and Factory Access

PLM includes features that aren't normally available to the user, for maintenance and updates.

Update

From time to time we may e-mail you software updates. PLM has a built-in utility for installing these updates from your networked computer. We will send you instructions as needed.

Remote factory access

We have also provided a unique way for our software engineers to perform remote diagnostics, if there are ever any problems. **You have to specifically set up Remote Access using a web browser before we can start. We absolutely can't get into your PLM until you let us.**

The set up procedure requires a specific series of steps, each time you want to enable it. It's virtually impossible to perform these steps accidentally. For your protection, we've also included a feature where you must explicitly confirm our access.

If you think remote access may be appropriate, contact us by phone or e-mail. We'll set up a time for the session and give you instructions for enabling it.

Specifications

Audio:

S/N = 84 dB with 10 dB headroom (94 dB dynamic range), A-weighted

THD @ 1 kHz = .01%; IMD (IHF) = .01%

Frequency response = ± 0.5 dB 20 Hz – 20 kHz

Measured with analog i/o; expect slightly better results with digital i/o.

No change in audio quality with increased time compression.

For more Information

25-Seven Systems
1241 Superior Avenue East
Cleveland OH 44114 USA
888.257.2578 (US toll free) 216.241.7225
anytime tech support 216.622.0247
info@25-seven.com
www.25-seven.com

Warranty

25-Seven Systems, A Telos Alliance Company (hereinafter “25-Seven” and “we” or “us”) warrants Program Delay Manager (“PLM” and “the unit”) to be free from defects in material and workmanship for a period of one year from the date of receipt by the end-user.

This warranty is void if the unit is subject to Acts of God including (without limitation) lightning; improper installation or misuse including (without limitation) power line surges; accident; neglect or damage.

EXCEPT FOR THE ABOVE-STATED WARRANTY, 25-SEVEN MAKES NO WARRANTIES, EXPRESS OR IMPLIED (INCLUDING IMPLIED WARRANTIES OF MERCHANTABILITY AND FITNESS FOR A PARTICULAR PURPOSE).

In no event will 25-Seven, its employees, agents or authorized dealers be liable for incidental or consequential damages, or for loss, damage, or expense directly or indirectly arising from the use of PLM or the inability to use PLM either separately or in combination with other equipment or materials, or from any other cause.

In order to invoke this Warranty, notice of a warranty claim must be received by 25-Seven within the above-stated warranty period and warranty coverage must be authorized by us. If we authorize the performance of warranty service, we will supply a shipping address and return authorization number: the defective unit must be delivered to that address, shipping prepaid and with that authorization number clearly marked.

We at our option will either repair or replace the unit and such action shall be the full extent of 25-Seven’s obligation under this Warranty. After the unit is repaired or replaced, we will return it to the party that sent the unit and will pay the cost of ground shipping.

25-Seven’s authorized dealers are not authorized to assume for us any additional obligations or liabilities in connection with the dealers’ sale of the unit.