



# *UPMAX2251*

## 5.1-Channel Surround-Field Synthesizer

### User Guide

**Release Date:** January, 2004  
**Software Version:** 0.805 and Later



Linear Acoustic Inc.  
Phone: 888-292-3117  
FAX: 973-267-4525  
email: [www.LinearAcoustic.com](http://www.LinearAcoustic.com)

---

---

## ***Warranty Information***

**DISCLAIMER OF WARRANTIES:** Products manufactured by Linear Acoustic Inc. are warranted against defects in material and workmanship for a period of two (2) years from the date of purchase. **THERE ARE NO OTHER IMPLIED OR EXPRESS WARRANTIES AND NO WARRANTY FOR MERCHANTABILITY OR FITNESS FOR A PARTICULAR PURPOSE.**

During the warranty period Linear Acoustic Inc. will repair, or at our discretion replace, components which prove to be defective, provided the unit is returned, shipped pre-paid to us directly with a return authorization (RA) number clearly marked on the packaging. **Please note, this RA number must be present or package will be refused and returned to sender.**

All requests for repairs MUST include the unit serial number to ensure quick and accurate service.

**DEFECTS CAUSED BY UNAUTHORIZED MODIFICATIONS, MISUSE OR ACCIDENTS, UNAUTHORIZED CUSTOMER REPAIRS, OR ANY FURTHER DAMAGE CAUSED BY INADEQUATE PACKAGING FOR SERVICE RETURN ARE NOT COVERED BY THIS WARRANTY.**

**PLEASE SAVE THE SHIPPING CARTON AND ALL PACKING MATERIALS. FAILURE TO RETURN UNIT IN ORIGINAL SHIPPING CARTON AND PACKING MATERIALS WILL RESULT IN A CHARGE FOR NEW SHIPPING MATERIALS.**

**LIMITATION OF PERIOD OF ACTION ON CONTRACT:** No action, regardless of form, arising out of the transactions under this agreement may be brought by buyer, its successors, agents and/or assigns, more than three years from date of purchase.

**LIMITATION OF LIABILITY:** It is understood and agreed that Linear Acoustic's liability whether in contract, in tort, under any warranty, in negligence or otherwise shall not exceed the cost of repair or replacement of the defective components and under no circumstances shall Linear Acoustic be liable for incidental, special, direct, indirect or consequential damages, or loss of use, revenue or profit even if Linear Acoustic or its agents have been advised, orally or in writing, of the possibility of such damages.

# Table of Contents

<b>List of Figures</b> .....	vi
<b>Chapter 1: Introduction</b> .....	5
1.1 Principles of Operation.....	5
1.2 Signals and Levels .....	7
1.3 Downmix Compatibility .....	8
<b>Chapter 2: Connections and Setup</b> .....	9
2.1 Unpacking and Inspection .....	9
2.2 Installation .....	9
2.3 Rear Panel .....	10
2.3.1 Connection Ports .....	10
<b>Chapter 3: Applications</b> .....	13
3.1 Typical Scenarios .....	13
3.1.1 Two-Channel Commercials .....	14
3.1.2 Sporting Events .....	15
3.1.3 Music Awards-Type Events.....	16
3.2 Factory Presets .....	17
<b>Chapter 4: Menus</b> .....	19
4.1 Main Menu.....	19
4.1.1 Modify Processing Menu .....	19
4.1.2 Setup Menu .....	21
4.1.3 System Info .....	23
4.1.4 System Options.....	23
4.1.5 Lock Front Panel.....	24
<b>Chapter 5: Specifications</b> .....	25

## List of Figures

1-1	Audio Block Diagram .....	6
2-1	Rear Panel .....	10
3-1	UPMAX 2251 in a commercial upmixing application .....	14
3-2	UPMAX 2251 in a live sports application .....	15
3-3	UPMAX 2251 in a music awards-type program .....	16
4-1	Main Screen showing level meters to the left and menus to the right. ....	19
4-2	Modify Processing menu; scroll down to access Ext L/R Mix (as shown on right menu) ...	20
4-3	Setup menu .....	21
4-4	Save Preset menu before (left) and after (right) saving .....	23

# Chapter 1: Introduction

---

The Linear Acoustic upMAX 2251 produces a 5.1 channel audio signal that is perfect for eventual transmission via Dolby Digital (also known as AC-3) to all consumers. The unit accepts a 2-channel input and “upmixes” it to fill as many of the 5.1 output channels as the user selects. Any input signal from mono to LtRt (Left Total/Right Total) surround encoded audio can be applied to the Main Input and an output will be produced that maintains consistency with other 5.1 channel programming.

Further, external discrete sources of audio such as announcer or stereo crowd can be applied to the unit via its Mix Inputs and can be selectively mixed with the audio produced by the upmixing process. A subwoofer, or LFE channel can also be selectively created from the Main Input audio or via the discrete LFE Mix Input.

The upMAX 2251 provides the following features:

- Advanced upmixing algorithm for stable, convincing surround experience.
- Fully compatible with all surround formats including Dolby Digital
- Upmixed surround field is infinitely adjustable in width and depth.
- External inputs allow mixing of discrete and upmixed audio signals.
- Relay bypassed digital inputs for “mission critical” broadcast applications.
- Simple front panel user interface and display.
- Optional HDSDI (SMPTE 292M) input module (available Q1, 2004)

## 1.1 Principles of Operation

The upMAX 2251 contains two paths for audio signals. The first path contains an upmixer, a bass extension filter to create the LFE (Low Frequency Effects) or subwoofer channel, and a simple but powerful set of mix controls to vary each element of the surroundfield. The second path provides discrete inputs for the Center, LFE, Ls (Left Surround), Rs (Right Surround), Lf (Left Front) and Rf (Right Front) channels. The upmixed and discrete outputs are selectively combined to allow for the addition of specific audio elements to the upmix-derived elements.

Please refer to Figure 1-1. It should be noted that this diagram is a general representation of signal flow. Please consult the appropriate section of this manual for an accurate description of actual functionality.

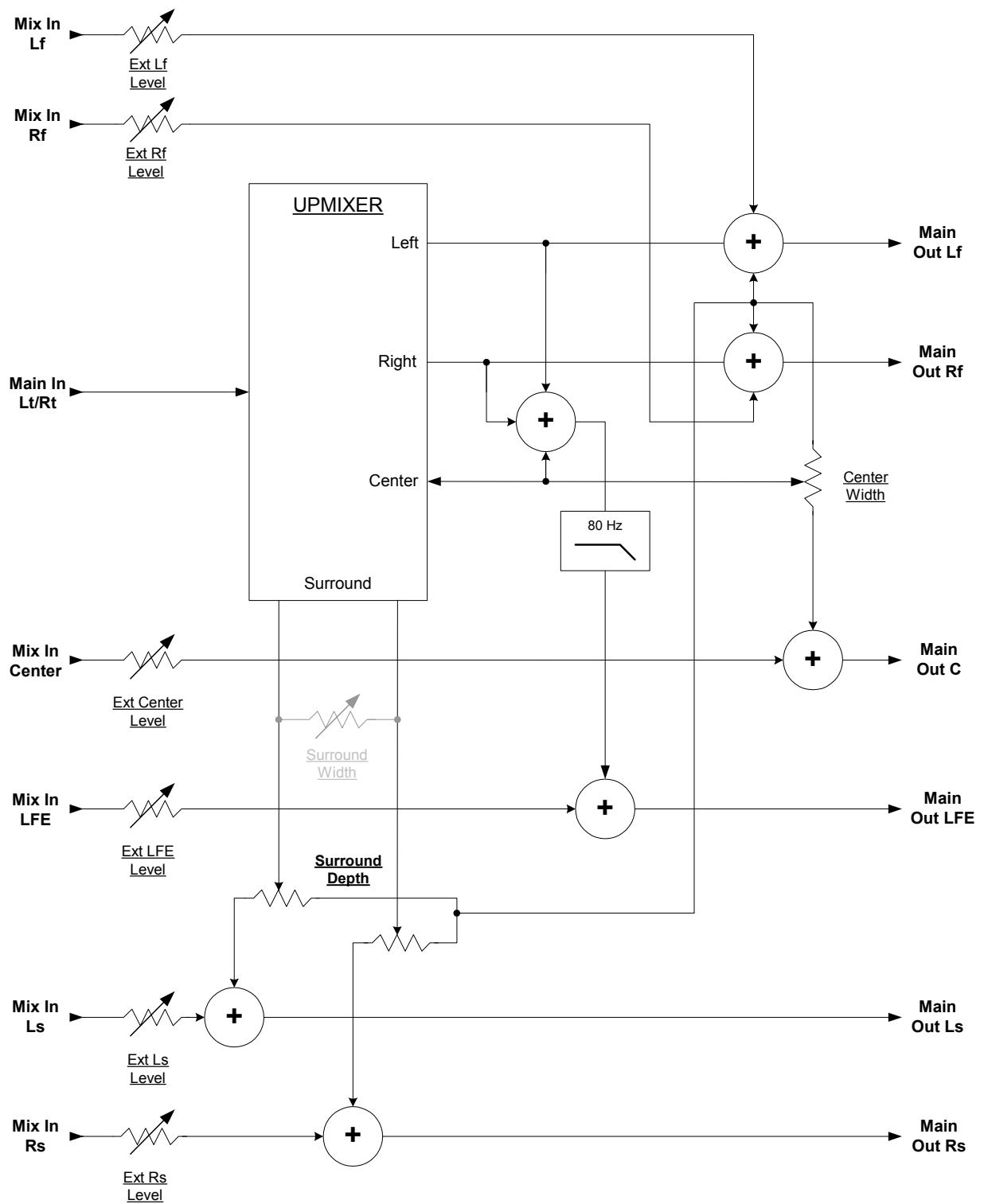

Figure 1-1 Audio Block Diagram

Two-channel audio is applied via the Lt/Rt Main Input. The audio is upmixed to produce Left, Right, Center, and Surround signals. The Left and Right outputs of the upmixer are passed unmodified to the Left and Right Main Output.

The Center channel output of the upmixer is passed through the **Center Width** control which varies the amount of center channel audio present at the Center Main Output versus how much is summed back into the Left and Right Main Output. A setting of 100% indicates that all of the upmixed Center audio is being fed to the Center Main Output, while 0% indicates that all of the upmixed Center audio is being fed back into the Left and Right Main Output. The 0% setting is the same as “Phantom Center” mode common on some decoders.

The Left, Right, and Center outputs of the upmixer are combined then 80Hz low pass filtered and when selected via the **LCR Sum To LFE** switch are passed via the LCR Sum Level control to the LFE Main Output.

The Surround output of the upmixer is passed through the **Surround Depth** control which varies the amount of surround information present at the Ls/Rs Main Output versus how much is summed back into the Left and Right Main Output. A setting of 100% indicates that all of the upmixed Surround audio is being fed to the Ls/Rs Main Output, while 0% indicates that all of the upmixed Surround audio is being mixed back into the Left and Right Main Output.

All outputs of the upmixer can also be selectively combined with signals applies to the Mix Inputs. The Mix Inputs are available for all channels and have **Mix Level** controls that vary from off to +6dB. Note that the +6dB range is provided for convenience, but a full-scale signal applied to these inputs can be increased to clipping, so settings above 0dB should be used carefully and sparingly.

## 1.2 Signals and Levels

The Linear Acoustic upMAX 2251 is calibrated for -20dBFS environments, but will work fine with other reference levels with the minor caveat that the analog LtRt utility output (on the LtRt/Aux DB-25 connector) is fixed at -20dBFS=+4dBu.

The sample rate of the upMAX 2251 is nominally 48kHz, but the unit will run at other sample rates as determined by the signal applied to the AES REF input. Please note that currently this causes the test tones to change slightly in frequency, but has no effect on the program audio.

Below is a list of the inputs and outputs of the upMAX 2251:

- Lt/Rt Main Input - Main input to upmixer
- Mix Inputs (C/LFE, Ls/Rs, Lf/Rf) - Direct mix inputs to the main output channels

- Main Outputs (Lf/Rf, C/LFE, Ls/Rs) - Main audio outputs in SMPTE 320M format
- LtRt Main Output - A utility two-channel downmix of the 5.1 channel program (this output is also available as an analog signal on the LtRt/Aux connector)

## 1.3 Downmix Compatibility

Downmixing is the process where the individual channels of a Dolby Digital signal are combined in order to be reproduced from a given number of channels. For example, a 5.1 channel program must be downmixed to be reproduced from a stereo speaker system and so the left and right channels are combined with the left and right surround signals and an attenuated version of the center channel before being output as a stereo signal. This type of signal is called LoRo (for Left only/Right only).

Downmixing may also produce an LtRt compatible signal by performing a pseudo-surround encode. A 90-degree phase shift is applied to the surround signals in the Dolby Digital encoder prior to the actual encoding stage so that after downmixing from 5.1 to 2-channels in the consumer decoder the signal can be heard in surround by the many consumers that only have a matrix surround decoder.

An extremely important design goal of the Linear Acoustic upMAX 2251 was that the output be downmix compatible. Not only stereo and surround, but also mono- and it had to sound good in 5.1! A tall order that has been satisfied.

One important thing to remember is that to ensure widest compatibility, the Dolby Digital encoder must be set to apply a 90-degree phase shift. Luckily, this is the default position for most of the presets, however please consult the encoders user manual to find the menu location where this setting can be checked.



## Chapter 2: Connections and Setup

---

This chapter covers all required connections for the Linear Acoustic upMAX 2251.

### 2.1 Unpacking and Inspection

Before unpacking the unit, inspect the outer carton for shipping damage. If the carton shows damage, inspect the unit in those areas. Please save the carefully designed shipping carton and packing materials. In the unlikely event that the unit needs to be returned to the factory, alternate cartons or packing materials may not be adequate and can cause damage not covered by warranty.

The following essential items are provided with the unit:

- Warranty information: Fill out and return the postage-paid warranty card (please) to Linear Acoustic to ensure your software and documentation are kept up to date.
- One power cord (US style).
- Bag containing rack-mount screws and washers, a male DB-25 connector and shell for either the GPI/O or LtRt/Aux Outputs, and this manual.

### 2.2 Installation

upMAX 225 installation requires:

- three standard rack space units with ADEQUATE VENTILATION;
- standard 75 $\Omega$  BNC cables for digital signal connections;

To connect to digital equipment with 110  $\Omega$  XLR connectors, use impedance-matching transformers (available from Canare, Neutrik and other manufacturers).

- an AES reference supplied to the **AES REF** input *PRIOR* to powering the unit on.
- a suitable monitoring system.

We recommend a multichannel listening environment with at least six speakers to properly monitor a 5.1-channel program. An inexpensive system (less than \$400) available from Klipsch easily satisfies this requirement.

## 2.3 Rear Panel

The rear panel of the upMAX 2251 contains its electrical I/O.

---

**WARNING:** Before applying power, check the **Voltage Selector** switch.

---

### 2.3.1 Connection Ports

All of the upMAX 2251's connections are on the rear panel and are described in detail below. See Chapter 5: *Specifications* for specific pinouts.

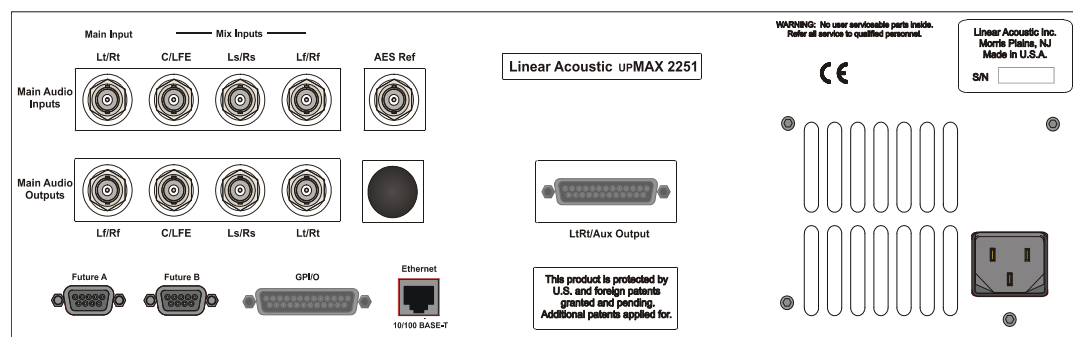

**Figure 2-1** Rear Panel

- **Main Audio Input:** Connect the PCM signal which will be upmixed to create a 5.1 channel signals to this input.
- **Mix Inputs:** PCM signals connected to these inputs can be selectively mixed with the output of the upmixing algorithm. These are useful for adding announcer via the **C** (center) input, or stereo “natural,” “crowd,” or “ambience” audio via the **Ls/Rs** (Left surround/Right surround) inputs. **Lf/Rf** (Left front/Right front) inputs are useful for placing audio in the left and right main outputs with no additional processing.
- **Main Audio Outputs:** Main processed digital audio outputs with the SMPTE 320M standard channel configuration: **Left/Right, Center/LFE, Left Surround/Right Surround**. An Lt/Rt compatible downmix of the 5.1 channel output is always available on the **Lt/Rt** output connector and is useful for monitoring or feeding systems such as NTSC which support only two audio channels.

---

**NOTE:** The main audio inputs are hard-bypassed to the Main Audio Outputs during boot and bypass (power off) conditions to support mission-critical applications. Under these circumstances, each input connector bypasses to the output connector directly below it passively maintaining audio continuity.

---

- 
- **AES REF:** Connect an AES plant reference signal to this connector (*not a video or word clock reference*). The signal may be an AES Black or AES signal containing audio.

---

**NOTE:** *A valid AES signal is required on the AES REF connector for the system to operate (not video or word clock).*

---

- **Lt/Rt/Aux Output:** This is a combination balanced analog and AES compatible digital output of the LtRt version of the main program audio.
- **GPI/O:** Connect to the GPI/O outputs of your automation system or routing or master control switcher to control special processor functions and recall presets. Note that GPI A and B require a held contact closure to ground for the duration of the function. However, GPI 1-6 require only a momentary contact closure to ground; if held, other numerical GPIs cannot be selected.
- **ETHERNET:** Automatically senses 10 or 100BASE-T Ethernet connectivity. The upMAX 2251 will appear on the network as: upMAX followed by the units serial number (i.e. upMAX-04301). The units workgroup is defaulted to WORKGROUP with no password. This connection is primarily used to support a software remote control running on a standard PC clone via a standard network connection.
- **Metadata In:** Connect to the Professional Audio Metadata output of a VANC de-embedder or Dolby E decoder to input external metadata (not currently supported, awaiting approval from Dolby Laboratories).
- **Metadata Out:** Connect to the metadata input of a Dolby E or Dolby Digital encoder (not currently supported, awaiting approval from Dolby Laboratories).



## Chapter 3: Applications

---

The upMAX 2251 is intended to be used either in the production or distribution stages of 5.1 channel programming, and also selectively in transmission environments. Cable and satellite facilities may find it useful as the distribution and transmission sections are usually very close together. For terrestrial emission (transmission) applications such as at DTV stations, the Linear Acoustic OCTiMAX 5.1 may be a more appropriate choice as it contains requisite dynamic range processing and additional useful features such as voice-over.

**The Linear Acoustic upMAX 2251 is *not* a substitute for a good, discrete multichannel mix (if one is available), rather it is a useful tool to create one!**

That being said, the upMAX 2251 *is* an excellent tool useful in either creating a 5.1 channel version of a program when few or no other elements exist, and also for creating a solid foundation for a true discrete multichannel mix.

This chapter discusses several applications of the upMAX 2251:

- Integrating 2-channel commercials into a 5.1 channel program
- Creating a 5.1 channel sports program from stereo plus natural sources
- Use for music programming
- Discussion of presets stored in the unit

### 3.1 Typical Scenarios

Below are some application examples to give users some guidance in real-world situations. However, before continuing, it is absolutely imperative that a proper multichannel monitoring environment be set up and *calibrated* before **every** mix. If the mix cannot be heard properly, then it cannot be created properly. Users are advised to obtain copies of the *Dolby Surround Mixing Manual* and the *Dolby Digital Professional Encoding Manual*, both available from the Dolby Laboratories web site ([www.dolby.com](http://www.dolby.com)) for detailed, accurate information on both the monitoring and mixing processes.

The Linear Acoustic upMAX 2251 is useful almost anywhere a multichannel mix must be created. From hands-on adjust-as-you-go environments like a music awards program to set-and-forget applications like helping two-channel commercials fit into 5.1-channel programming, the upMAX 2251 is the answer.

### 3.1.1 Two-Channel Commercials

One of the largest complaints viewers of digital and high definition television programming is the annoying fact that stereo commercials don't seem to "fit" into the 5.1-channel program. This is because in many cases, the commercials are simply transmitted on the Left and Right channels of a 5.1-channel program. The net result is that during the program, dialogue comes from the center speaker, but at commercial or station breaks, all of the dialogue comes from the left and right speakers. It can be a jarring experience.

The first application is one where the upMAX 2251 processes the stereo material allowing it to fit nicely within a 5.1 channel program. Figure 3-1 shows this scenario.

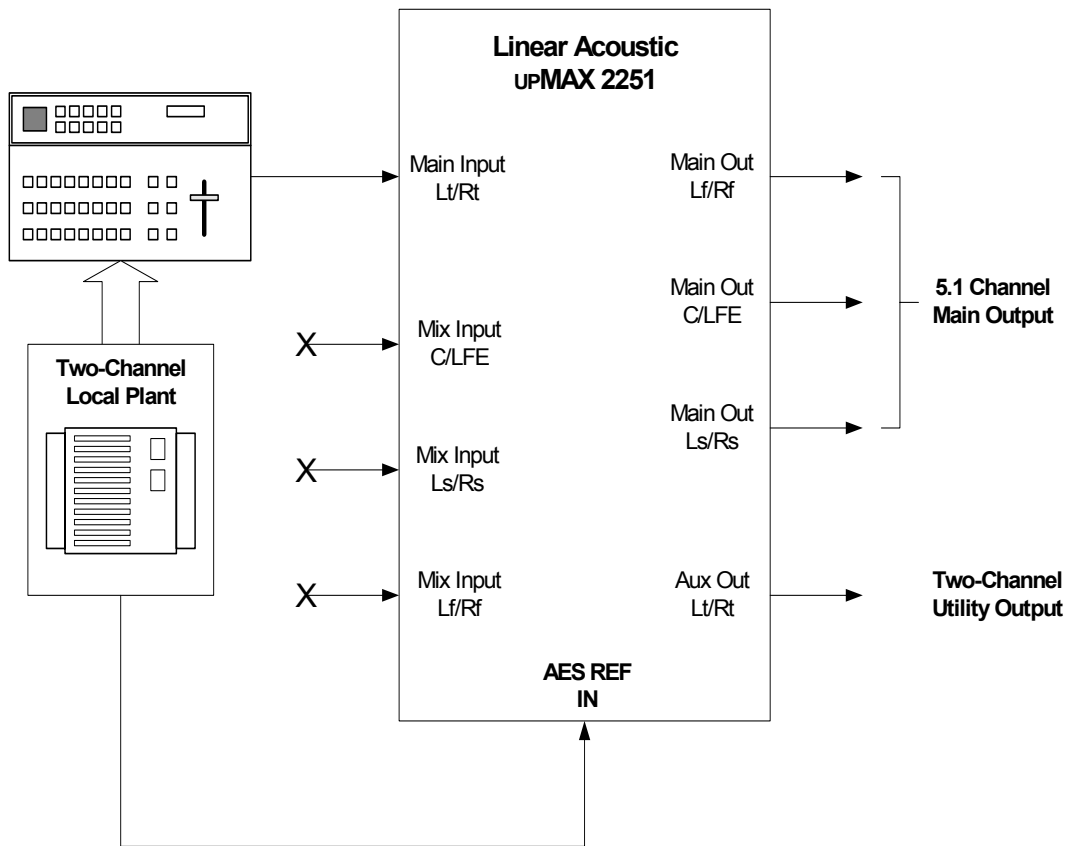
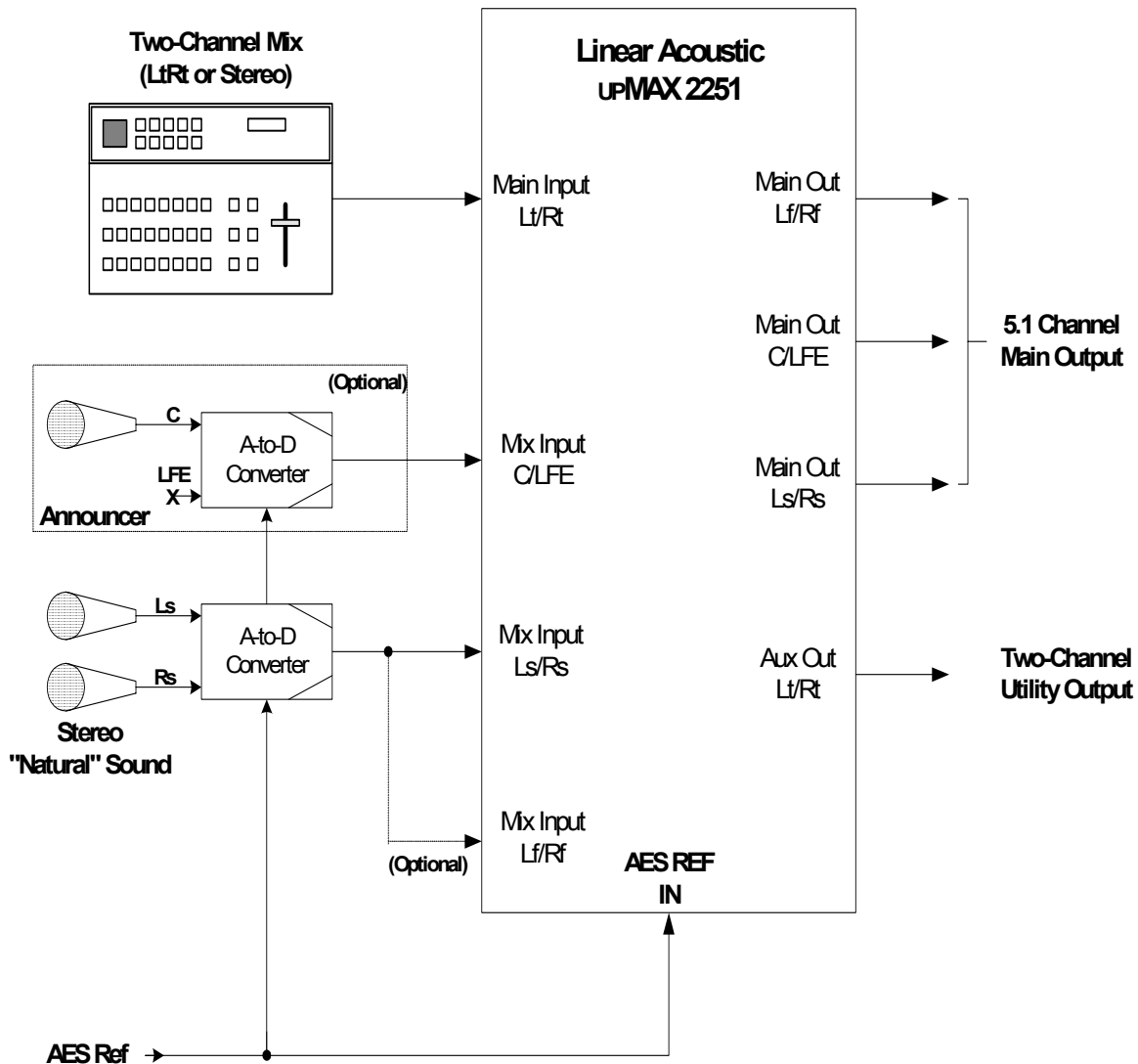

**Figure 3-1** upMAX 2251 in a commercial upmixing application

Note that the two channel material is simply input to the upMAX 2251 and a 5.1 channel signal is available at the output. Either the **Commercial Discrete** or **Commercial Cntr Spread** presets can be chosen, and are explained in detail at the end of this chapter.

### 3.1.2 Sporting Events

Figure 3-2 shows how a sporting event with a stereo mix, a stereo “natural” or ambience mix, and an optional dry announcer mix can be easily combined into a very convincing 5.1-channel program.



**Figure 3-2** upMAX 2251 in a live sports application

Note that if the announcer is already present in the main stereo mix (applied to the LtRt Main Input), then no additional announcer input is required as it will automatically be up-mixed into the Center channel output.

### 3.1.3 Music Awards-Type Events

Figure 3-3 shows how a music awards-type program can be greatly simplified by the use of an upMAX 2251. The main stereo or surround mix of the program is applied to the LtRt Main Inputs, while crowd noise, reverb, ambience, and selective music cues are selectively applied to the Ls/Rs and Lf/Rf Mix inputs. All announce microphones can be either part of the main mix or applied as a separate feed to the Center Mix Input.

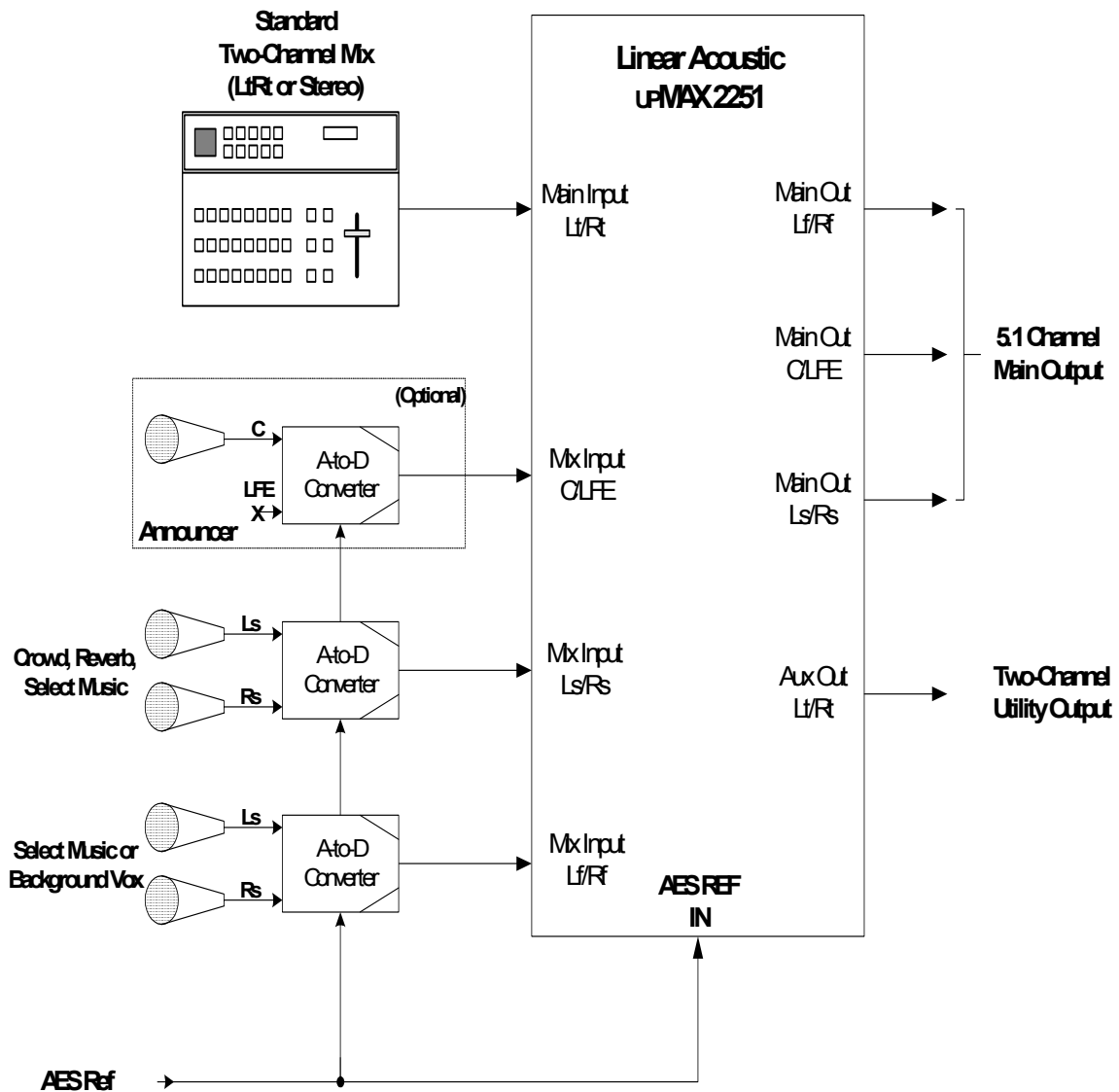

Figure 3-3 upMAX 2251 in a music awards-type program



## 3.2 Factory Presets

To get users up and running as quickly as possible, a few basic presets have been created for different situations. The name of the game with this unit is “play”. There is no possible way that presets appropriate for every situation could be generated, so we have included a few to get you started. By all means, make adjustments, listen, store your new preset with a name of your choice when you get it just right (we even have some Swedish characters in there).

The upMAX 2251 ships with the following factory presets:

- **Reference Settings** - Stock settings, a good place to start from scratch as all settings are in a reasonable “detent” position. Start here if you are unsure.
- **Music Cntr Spread** - Straight two-channel to 5.1 channel upmixing, with the center channel spread across the Left, Center, and Right outputs. This is very useful for programming that either contains dialogue with music or is just mono dialogue as it nicely fills the front three channels, and feeds the surrounds when appropriate.
- **MUSIC FULLCENTER** - Again, straight two-channel to 5.1 channel upmixing, but with the Center channel kept discrete. Useful for film mixes and certain music mixes. Two-channel mono programs will be reproduced from the Center channel only.
- **LIVE 4-CH to 5.1CH** - Couples a straight two-channel to 5.1 channel upmix with external surround information applied to the Ls/Rs Mix Inputs. Useful for a sports mix where a two-channel main program and a 2-channel natural or ambience mix are available.
- **LIVE 4-CH and ANNOUNCE** - Again, couples a straight two-channel to 5.1 channel upmix with external surround information applied to the Ls/Rs Mix Inputs, but also allows an announcer to be mixed into the Center channel via the Center Mix Input.
- **COMMERCIAL SHALLOW** - Straight two-channel to 5.1 channel upmix with the Surround audio positioned closer to the front channels. The Center channel is spread by the standard 33%.
- **COMMERCIAL DEEP** - Straight two-channel to 5.1 channel upmix with the Surround audio positioned all the way to the back and the Center channel spread by the standard 33%



## Chapter 4: Menus

This chapter discusses how to use the front panel LCD interface to access the menus. Most of it is rather obvious, and a bit of experimentation will quickly make you comfortable navigating through the submenus. If in doubt, use the Left Arrow to back out towards the Main menu. The menus and submenus are structured to access more complex functionality as you go deeper into the hierarchy. Almost every important adjustment can be made from the first three menu levels.

### 4.1 Main Menu

Figure 4-1 shows the main screen. The top eight meters show input activity for the Main Input (Lt/Rt) and the Mix Inputs (C/LFE, Ls/Rs, Lf/Rf). The bottom eight meters show the output activity for the Main AES Outputs (Lf/Rf, C/LFE, Ls/Rs, Lt/Rt). The sub-menus to the right of the meters are used to access the processor's functions, which are described in this chapter.

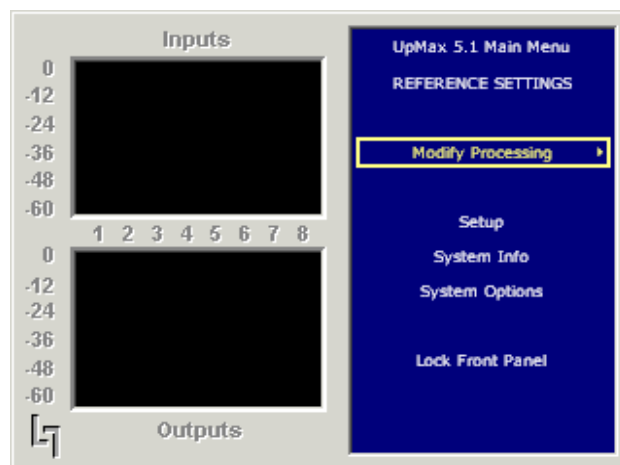

**Figure 4-1** Main Screen showing level meters to the left and menus to the right.

#### 4.1.1 Modify Processing Menu

The **Modify Processing** menu controls all of the audio functions provided by the upMAX 2251. As all of the settings do not fit onto one screen, it is necessary to scroll to the bottom (using the Down Arrow). Figure 4-2 shows the selections available in the Modify Processing menu:

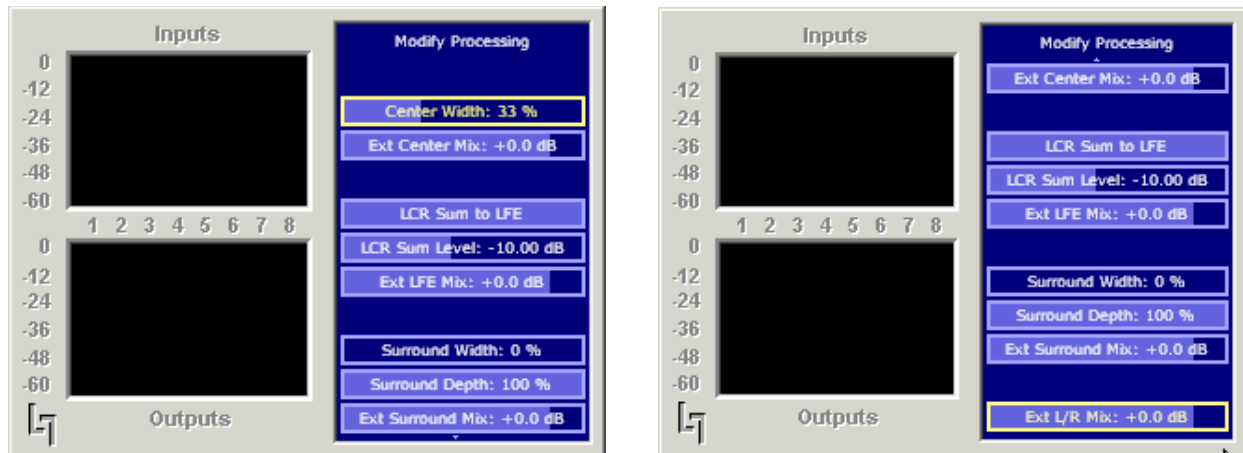

**Figure 4-2** Modify Processing menu; scroll down to access Ext L/R Mix (as shown on right menu)

The **Modify Processing** menu is broken into four major sections, Center channel controls, Low Frequency Effects (LFE) channel controls, Surround controls, and Left Front/Right Front (Lf/Rf) controls. Each section has specific controls for both the upmixer output signals (where appropriate) and for the external Mix Inputs. Note that the upmixer controls have no effect on the external Mix Inputs, these input are kept fully discrete from input to output. Below, each of the controls is presented with the default setting in **bold**:

#### Center:

- Center Width: controls how much of center channel output of the upmixer is spread back into the Left and Right channel Main Outputs of the unit; Default **33%**
- Ext Center Mix: controls how much attenuation is applied to the discrete external Center channel Mix Input is mixed into the Center channel Main Output; Default **0dB**

#### LFE:

- LCR Sum to LFE: On/Off selection; Default **On** (highlighted)
- LCR Sum Level: controls how much of a 120Hz low pass filtered sum of the Left, Center, and Right outputs of the upmixer is fed to the LFE channel Main Output; Default **-10dB**
- Ext LFE Mix: controls how much attenuation is applied to the discrete external LFE channel Mix Input is mixed into the Center channel Main Output; Default **0dB**

**Surround:**

- Surround Width (not presently active): controls how much separation is produced between the Left Surround (Ls) and Right Surround (Rs) outputs of the upmixer, where 100% means maximum separation and 0% means minimum separation (i.e. mono); Default: **0% (fixed)**
- Surround Depth: controls back-to-front panning of the Surround output of the upmixer, where 100% equals full signal from the Left Surround and Right Surround Main Outputs and 0% equals surround fully mixed back into the LCR outputs; Default: **100%**
- Ext Surround Mix: controls how much attenuation is applied to the discrete external Left and Right Surround channel Mix Inputs are mixed into the Left and Right Surround channel Main Outputs; Default **0dB**

**L/R:**

- Ext L/R: controls how much attenuation is applied to the discrete external Left Front and Right Front channel Mix Inputs are mixed into the Left and Right channel Main Outputs; Default **0dB**

**4.1.2 Setup Menu**

The **Setup** menu shows the current preset that the upMAX 2251 is running and allows access to both recall other presets or store a modified preset:

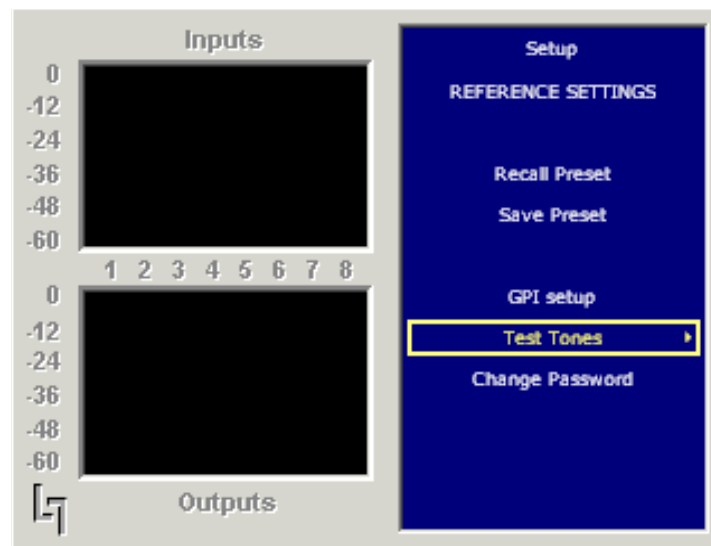

**Figure 4-3** Setup menu

The **Setup** menu also allows for configuration of the GPI Inputs (currently not enabled), selection of Test Tones for setup, as well as changing a password (if one has been set). Below are detailed descriptions of these submenus:

**GPI Setup** allows configuration of the GPI A and B inputs. Each can be set to provide a specific function that will be active while the GPI pin (A or B) is held in a low state. When GPI is enabled (the **Enable GPI** menu item is highlighted), the unit waits for an external command via the GPI/O port and nothing else can be changed. To make a change to the type of action each will produce, disable GPI by de-selecting the menu item. The available functions include the following:

- **Disable**
- **Upmix Off/On** - Holding GPI low causes the upmixer to be activated
- **Upmix On/Off** - Inverted operation of above; Holding GPI low causes the upmixer to be de-activated
- **Mute All Ext Inputs** - Holding GPI low causes the Ext Center, LFE, Ls/Rs, and Lf/Rf inputs to be muted.
- **Mute Ext Center** - Holding GPI low causes the External Center input to be muted
- **Mute Ext LFE** - Holding GPI low causes the External LFE input to be muted
- **Mute Ext Surround** - Holding GPI low causes the External Surround inputs to be muted
- **Mute Ext LfRf** - Holding GPI low causes the External Left front and Right front inputs to be muted

**Test Tones** – Multiple setup tones are available to calibrate the OCTiMAX 5.1 and other downstream equipment. The **Level** control is self-explanatory, but is set at the standard – 20 dBFS reference level and adjusts the overall level of the test signals. The available test signals are:

- Sine – 1 kHz sine wave (frequency lower at lower sample rates)
- Voice – Voice ID of all selected channels
- Pink Noise – Equal energy-per-octave noise
- White Noise – Equal level-per-octave noise
- Brown Noise – Low-pass-filtered noise

- Brown Nose – Try it (can't be serious all the time- we'd crack)
- The last selection determines which channels will reproduce the selected test signals. It can be adjusted by cycling through all channels, all channels of just the main program (default), and individual channels.

**Change Password** – The password is either entered here for the first time or changed. Use the rotary knob and the right arrow key to enter your password, then select **Save**. You will be prompted several times, and then you will be reminded not to lose the password. *Please heed the warning!* If you do happen to lose it, please call us to assist recovery without losing presets. If you wish to remove the password, simply enter the old password, then enter nothing for the new one and select **Save**. You will be prompted a few times, and then it will be removed.

**Save and Recall Preset** – All configuration begins with a factory preset but these can be modified, stored, and recalled.

Saving a preset is a simple procedure. Adjusting any parameter in the **Modify Processing** menu appends an *M* to the name of the original preset to indicate that it has been modified but not yet saved yet. Figure 4-4 shows the **Save Preset** menu.

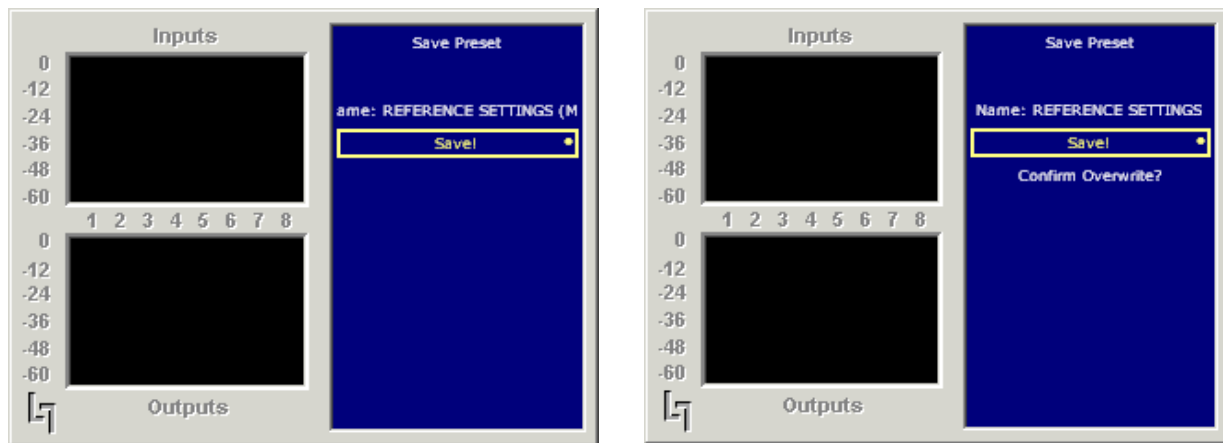

**Figure 4-4** Save Preset menu before (left) and after (right) saving

The **Save Preset** screen allows you to keep the existing name or rename and save using the arrow keys and the rotary encoder. If you remove the *M* and attempt to write over the previously saved preset name, you will be prompted to confirm that you wish to overwrite a stored preset.

---

**CAUTION:** *The system allows overwriting the factory stored presets, please rename!*

---

### 4.1.3 System Info

The **System Info** menu provides the following statistics:

- **Firmware Version**
- **CPU Usage** – Normally around 20%
- **Buffer Size**
- **Average SR** – Average Sample Rate
- **Samples Processed** – This is a useless (but fun) statistic

### 4.1.4 System Options

The **System Options** menu provides the following functions:

- **Master Bypass** – Relay bypass of Digital Inputs to Digital Outputs
- **LCD Shutoff** – Select the time-out for the LCD backlight. The backlight turns on once any control is pressed. The unit ships with a 15 minute setting to prolong the life of the backlight tube. Although the unit is rated for long life, it will not last forever and the entire costly LCD display must be replaced when it fails. We like the light show and the meters and have not had a display fail in two years of almost constant use, but we are being respectful of our customer's budgets!
- **Reinitialize** – Fast reset of the system software and audio drivers
- **Power Cycle** – Slow reset of the entire system. Select this to perform a full system re-boot and re-initialize; you are returned to the main menu.

### 4.1.5 Lock Front Panel

Select this menu to lock the front panel (funny enough).



## Chapter 5: Specifications

Table 5-1 Electrical Specifications

<b>Sampling Rate</b>	48 kHz ( $\pm 0.1\%$ ), 44.1 kHz ( $\pm 0.1\%$ )
<b>Output Delay</b>	14 ms (min.), optional one video frame (PAL or NTSC)
<b>Audio Word Length</b>	Up to 24 bits
<b>Digital Audio In</b>	Five BNC female connectors, AES-3ID-1995/SMPTE 276M
<b>Digital Audio Out</b>	Four BNC female connectors, AES-3ID-1995/SMPTE 276M
<b>LtRt/Aux Output</b>	25-pin female D-connector, +4 dBu balanced (LtRt output only)
<b>Metadata Input</b>	RS-485, 9-pin female D-connector on rear panel
<b>Metadata Output</b>	RS-485, 9-pin female D-connector on rear panel
<b>GPIO Port</b>	TTL level, 25-pin female D-connector
<b>Ethernet Port</b>	RJ-45 female jack connector
<b>Analog Outputs</b>	
<b>Frequency Response</b>	20 Hz–20 kHz, $\pm 0.5$ dB
<b>Distortion</b>	Less than 0.01% at 1 kHz Less than 0.02%, 20 Hz–20 kHz
<b>Dynamic Range</b>	Greater than 106 dB
<b>Output Connectors</b>	LtRt/Aux Output via 25-pin female D-connector
<b>Digital I/O</b>	
<b>Digital Audio Inputs</b>	Four unbalanced female BNC connectors compatible with AES-3ID-1995/SMPTE 276M specifications.
<b>Digital Audio Outputs</b>	Four unbalanced female BNC connectors compatible with AES-3ID-1995/SMPTE 276M specifications.
<b>REF Input</b>	One unbalanced female BNC connectors compatible with AES-3ID-1995/SMPTE 276M specifications.

Table 5-2 Mechanical Specifications

<b>Dimensions</b>	5.25 × 19 × 24 in (13.3 × 48.3 × 61 cm)
<b>Net Weight</b>	25 lb (12.6 kg) approx.
<b>Shipping Weight</b>	32 lb (15.75 kg) approx.
<b>Power Requirements</b>	115/220 VAC, switchable, 50–60 Hz
<b>Power Consumption</b>	40 W maximum

Table 5-3 Environmental Specifications

<b>Operating Temperature</b>	0°C to 50°C, fan cooled
<b>Non Operating Temperature (Storage)</b>	-20°C to +70°C
<b>Humidity</b>	Up to 98% relative humidity, non-condensing
<b>EMC Radiation Limits</b>	FCC Part 15 Class A, ICES-003

## Metadata Input Port

9-pin female D-connector with full-duplex RS-485 protocol running at 115 kbps. Pinout is compatible with SMPTE 207M.

Table 5-4 Metadata Input Port Pinout

Pin	Connection
1	Shield
2	TX A asynchronous data out -
3	RX B asynchronous data in +
4	Ground
5	NC
6	Ground
7	TX B asynchronous data out +
8	RX A asynchronous data in -
9	Shield

## Metadata Output Port

9-pin female, RS-485, full-duplex, 115 kbps. Pinout is compatible with SMPTE 207M.

Table 5-5 Metadata Output Port Pinout

Pin	Connection
1	Shield
2	RX A asynchronous data in -
3	TX B asynchronous data out +
4	Ground
5	NC
6	Ground
7	RX B asynchronous data in +
8	TX A asynchronous data out -
9	Shield

## Ethernet Port

The Ethernet port is a standard RJ-45 female connector that supports 10 or 100BASE-T.

## GPI/O Parallel Control Port

TTL level controls, active Low. GPI A and B are held low to activate their assigned function, while GPI 1-6 require momentary contact to ground to activate their functions. The 5-V output for external GPO indicators is limited by a self-resetting fuse.

Table 5-6 GPI/O Parallel Control Port Pinout

Pin	Function	Pin	Function
1	+ 5 V (150 mA)	14	+ 5 V (150 mA)
2	GPI A (Hold Low = On)	15	Ground
3	GPI B (Hold Low = On)	16	Ground
4	GPI 1 (Momentary)	17	Ground
5	GPI 2 (Momentary)	18	Ground
6	GPI 3 (Momentary)	19	Ground
7	GPI 4 (Momentary)	20	Ground
8	GPI 5 (Momentary)	21	Ground
9	GPI 6 (Momentary)	22	Ground
10	No Connection	23	Ground
11	No Connection	24	GPO 1
12	GPO 2	25	Ground
13	Ground		

## Lt/Rt + 7/8 Analog Output

25-pin female D-connector. Uses similar pinout as DA-88 connector except that channel 4 has been replaced by an unbalanced AES digital output, and channels 2, 5, and 6 are not used.

Table 5-7 Lt/Rt + 7/8 Analog Output Pinout

Pin	Connection	Pin	Connection
1	Rt + Out	14	Rt – Out
2	Rt Ground	15	Lt + Out
3	Lt – Out	16	Lt Ground
4	No Connection	17	No Connection
5	<b>RESERVED</b>	18	<b>RESERVED</b>
6	No Connection	19	No Connection
7	No Connection	20	No Connection
8	No Connection	21	No Connection
9	No Connection	22	No Connection
10	No Connection	23	No Connection
11	No Connection	24	No Connection
12	No Connection	25	No Connection
13	No Connection		

